

**CADERNO DE PEÇAS
ESTRUTURA METÁLICA**

Sumário

Tabela de Peças	3
APOIO	5
CHAPA E CORRENTE	6
CONTRAVENTAMENTO	10
DIAGONAL	16
EMPENA	39
LINHA	42
PENDURAL	45
TERÇA	46

Função da peça		Tipo de Perfil
PN	PENDURAL	1-U100X50X3.04 (II)
EM	EMPENA	2-U100X50X4.75 (II)
L	LINHA	3-L 1.1/4 X 1/8" (II)
D	DIAGONAL	4-L 1 X 1/8" (II)
A	APOIO	5-U100X40X2.66 (II)
CV	CONTRAVENTAMENTO	6-U100*40*2.66
CR	CORRENTE	7-C127*50*2.28
R	REFORÇO	8-D ø 6.35
TR	TERÇA	9-L 1/2 X 1/8"
CP	CHAPA	10-D ø 9.53
		11-PL e=6.3 mm

Tabela de Peças							
Posição	Qtd.	Nome	Perfil	Comprimento [mm]	Comprimento Total [m]	Peso [kg]	Peso Total [kg]
A/1	18	Apoios	U100X50X4.75 (I)	4099	73,782	56,99	1025,82
A/2	18	Apoio	U100*40*2.66	428	7,704	1,51	27,12
A/3	18	Apoios	U100X50X3.04 (I)	4099	73,782	37,2	669,52
CP/1	18	Chapa	PL e=6.3 mm	100	1,8	0,5	8,99
CR/1	1	Corrente	L 1/2 X 1/8"	1074	1,074	0,59	0,59
CR/2	23	Corrente	L 1/2 X 1/8"	2122	48,806	1,17	26,97
CR/3	2	Corrente	L 1/2 X 1/8"	2067	4,134	1,14	2,28
CR/4	23	Corrente	L 1/2 X 1/8"	1197	27,531	0,66	15,21
CR/5	45	Corrente	L 1/2 X 1/8"	2001	90,045	1,11	49,76
CR/6	26	Corrente	L 1/2 X 1/8"	1999	51,974	1,1	28,71
CR/7	2	Corrente	L 1/2 X 1/8"	2148	4,296	1,19	2,37
CR/8	1	Corrente	L 1/2 X 1/8"	1996	1,996	1,1	1,1
CR/9	1	Corrente	L 1/2 X 1/8"	1195	1,195	0,66	0,66
CR/10	1	Corrente	L 1/2 X 1/8"	2157	2,157	1,19	1,19
CR/11	22	Corrente	L 1/2 X 1/8"	2135	46,97	1,18	25,95
CR/12	22	Corrente	L 1/2 X 1/8"	2051	45,122	1,13	24,93
CR/13	7	Corrente	L 1/2 X 1/8"	1058	7,406	0,58	4,09
CV/1	8	Contravent	D ø 6.35	6179	49,432	1,57	12,6
CV/2	8	Contravent	D ø 6.35	6204	49,632	1,58	12,65
CV/3	5	Contravent	D ø 6.35	5669	28,345	1,44	7,22
CV/4	8	Contravent	D ø 6.35	5648	45,184	1,44	11,52
CV/5	8	Contravent	D ø 6.35	6191	49,528	1,58	12,62
CV/6	8	Contravent	D ø 6.35	6180	49,44	1,57	12,6
CV/7	6	Contravent	D ø 9.53	3153	18,918	1,59	9,55
CV/8	14	Contravent	D ø 9.53	3204	44,856	1,62	22,67
CV/9	6	Contravent	D ø 9.53	3153	18,918	1,59	9,55
CV/10	3	Contravent	D ø 6.35	5658	16,974	1,44	4,33
CV/11	1	Contravent	D ø 9.53	3286	3,286	1,66	1,66
CV/12	1	Contravent	D ø 9.53	3286	3,286	1,66	1,66
D/1	9	Diagonal	L 1.1/4 X 1/8"(I)	715	6,435	2,19	19,7
D/2	9	Diagonal	L 1.1/4 X 1/8"(I)	760	6,84	2,33	20,93
D/3	18	Diagonal	L 1.1/4 X 1/8"(I)	679	12,222	2,08	37,39
D/4	9	Diagonal	L 1.1/4 X 1/8"(I)	720	6,48	2,2	19,83
D/5	9	Diagonal	L 1 X 1/8" (I)	723	6,507	1,72	15,47
D/6	9	Diagonal	L 1 X 1/8" (I)	727	6,543	1,73	15,57
D/7	36	Diagonal	L 1 X 1/8" (I)	717	25,812	1,71	61,41
D/8	9	Diagonal	L 1 X 1/8" (I)	726	6,534	1,73	15,55
D/9	18	Diagonal	L 1 X 1/8" (I)	729	13,122	1,73	31,19
D/10	18	Diagonal	L 1 X 1/8" (I)	660	11,88	1,57	28,26
D/11	9	Diagonal	L 1 X 1/8" (I)	668	6,012	1,59	14,3
D/12	9	Diagonal	L 1 X 1/8" (I)	736	6,624	1,75	15,76
D/13	9	Diagonal	L 1 X 1/8" (I)	743	6,687	1,77	15,91
D/14	9	Diagonal	L 1 X 1/8" (I)	763	6,867	1,81	16,33
D/15	9	Diagonal	L 1 X 1/8" (I)	725	6,525	1,73	15,53
D/16	9	Diagonal	L 1 X 1/8" (I)	707	6,363	1,68	15,14
D/17	9	Diagonal	L 1 X 1/8" (I)	736	6,624	1,75	15,75
D/18	9	Diagonal	L 1 X 1/8" (I)	760	6,84	1,81	16,28
D/19	9	Diagonal	L 1 X 1/8" (I)	719	6,471	1,71	15,39
D/20	18	Diagonal	L 1 X 1/8" (I)	690	12,42	1,64	29,53
D/22	9	Diagonal	L 1.1/4 X 1/8"(I)	670	6,03	2,05	18,47
D/23	18	Diagonal	L 1 X 1/8" (I)	402	7,236	0,96	17,23
D/24	9	Diagonal	L 1 X 1/8" (I)	844	7,596	2,01	18,07
D/25	9	Diagonal	L 1 X 1/8" (I)	691	6,219	1,64	14,79
D/26	9	Diagonal	L 1.1/4 X 1/8"(I)	516	4,644	1,58	14,21
D/27	63	Diagonal	L 1.1/4 X 1/8"(I)	601	37,863	1,84	115,84
D/28	18	Diagonal	L 1.1/4 X 1/8"(I)	402	7,236	1,23	22,17
D/29	18	Diagonal	U100*40*2.66	642	11,556	2,19	39,36
D/30	9	Diagonal	L 1.1/4 X 1/8"(I)	715	6,435	2,19	19,7
D/31	9	Diagonal	L 1.1/4 X 1/8"(I)	760	6,84	2,33	20,93
D/32	9	Diagonal	L 1.1/4 X 1/8"(I)	720	6,48	2,2	19,83
D/33	9	Diagonal	L 1 X 1/8" (I)	723	6,507	1,72	15,47
D/34	9	Diagonal	L 1 X 1/8" (I)	727	6,543	1,73	15,57
D/35	36	Diagonal	L 1 X 1/8" (I)	717	25,812	1,71	61,41
D/36	9	Diagonal	L 1 X 1/8" (I)	726	6,534	1,73	15,55
D/37	18	Diagonal	L 1 X 1/8" (I)	729	13,122	1,73	31,19
D/38	9	Diagonal	L 1 X 1/8" (I)	668	6,012	1,59	14,3
D/39	9	Diagonal	L 1 X 1/8" (I)	736	6,624	1,75	15,76
D/40	9	Diagonal	L 1 X 1/8" (I)	743	6,687	1,77	15,91
D/41	9	Diagonal	L 1 X 1/8" (I)	763	6,867	1,81	16,33
D/42	9	Diagonal	L 1 X 1/8" (I)	725	6,525	1,73	15,53
D/43	9	Diagonal	L 1 X 1/8" (I)	707	6,363	1,68	15,14
D/44	9	Diagonal	L 1 X 1/8" (I)	736	6,624	1,75	15,75
D/45	9	Diagonal	L 1 X 1/8" (I)	760	6,84	1,81	16,28
D/46	9	Diagonal	L 1 X 1/8" (I)	719	6,471	1,71	15,39
D/47	9	Diagonal	L 1.1/4 X 1/8"(I)	670	6,03	2,05	18,47
D/48	9	Diagonal	L 1 X 1/8" (I)	844	7,596	2,01	18,07
D/49	9	Diagonal	L 1 X 1/8" (I)	691	6,219	1,64	14,79
D/50	9	Diagonal	L 1.1/4 X 1/8"(I)	516	4,644	1,58	14,21
D/51	63	Diagonal	L 1.1/4 X 1/8"(I)	601	37,863	1,84	115,84
D/52	18	Diagonal	L 1.1/4 X 1/8"(I)	7093	127,674	21,71	390,82

EM/1	18	Empena	U100*40*2.66	9385	168,93	34,19	615,48
EM/2	18	Empena	U100*40*2.66	983	17,694	3,59	64,65
EM/3	18	Empena	U100*40*2.66	1080	19,44	3,94	70,98
EM/4	18	Empena	U100*40*2.66	1070	19,26	3,91	70,36
EM/5	18	Empena	U100*40*2.66	1063	19,134	3,89	69,93
EM/6	18	Empena	U100*40*2.66	531	9,558	1,94	34,9
L/1	18	Linha	U100*40*2.66	1003	18,054	3,66	65,88
L/2	18	Linha	U100*40*2.66	1008	18,144	3,67	66,14
L/3	18	Linha	U100*40*2.66	1025	18,45	3,73	67,08
L/4	18	Linha	U100*40*2.66	1029	18,522	3,75	67,52
L/5	18	Linha	U100*40*2.66	3500	63	12,74	229,29
L/6	18	Linha	U100*40*2.66	1110	19,98	3,99	71,81
L/7	18	Linha	U100*40*2.66	774	13,932	2,68	48,27
L/8	18	Linha	U100*40*2.66	3500	63	12,8	230,35
PN/1	9	Pendural	U100X40X2.66 ([I])	520	4,68	3,75	33,79
PN/2	18	Pendural	U100X40X2.66 ([I])	524	9,432	3,79	68,14
R/1	18	Reforço	U100*40*2.66	1143	20,574	4,06	73,01
TR/1	15	Terça	C127*50*2.28	38500	577,5	173,28533	2599,28
TR/2	1	Terça	C127*50*2.28	38497	38,497	173,27	173,27

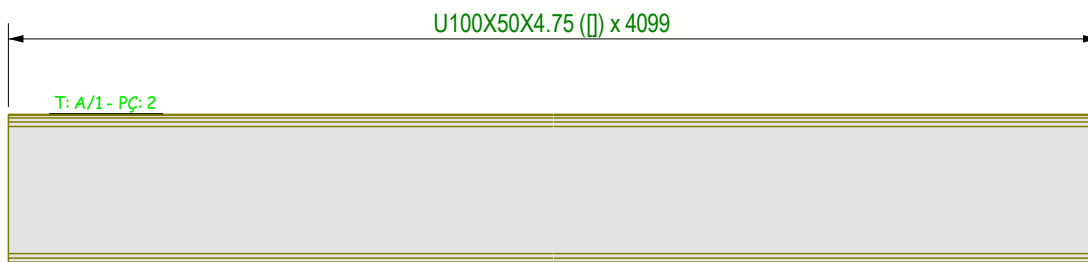

No. 18, Marc. A/1

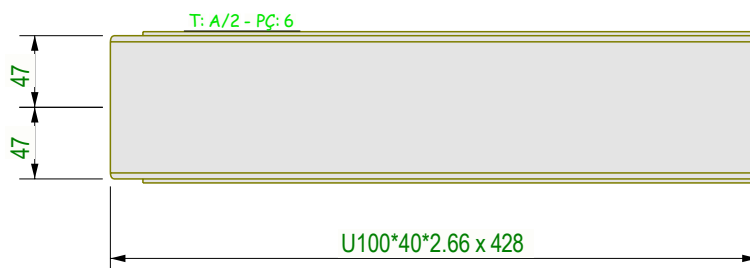
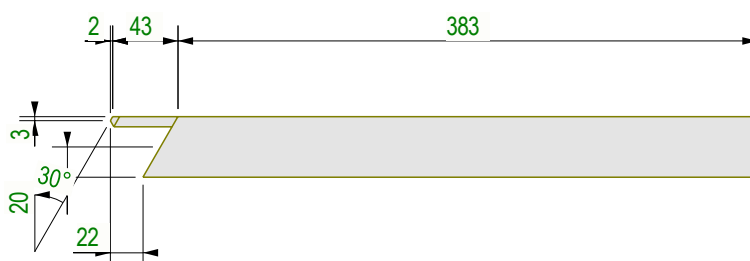

No. 18, Marc. A/2

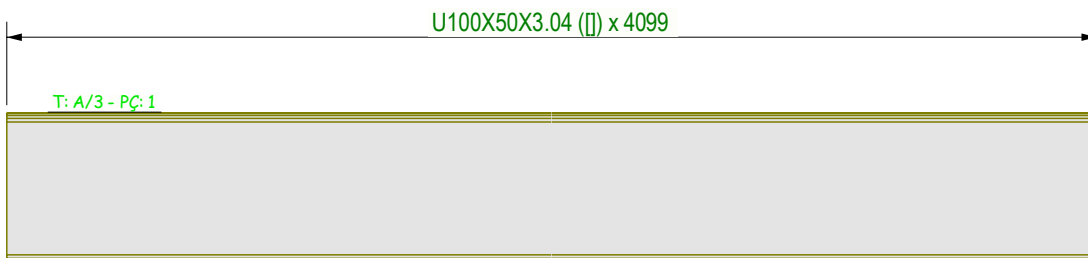

No. 18, Marc. A/3

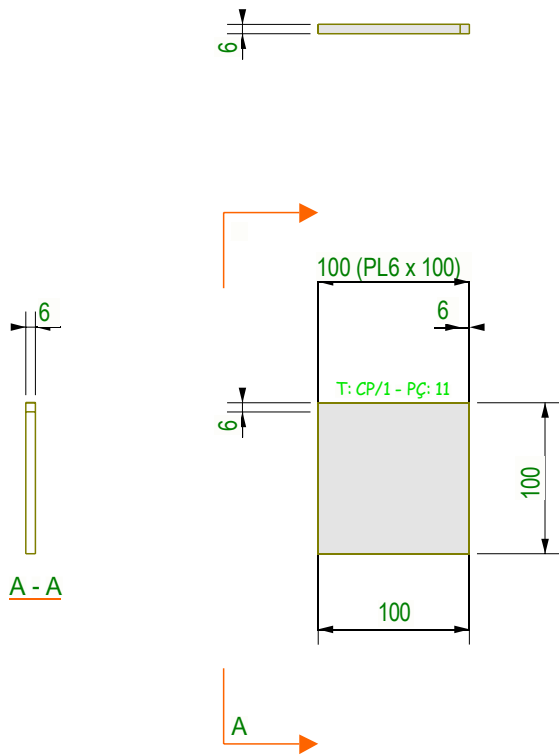

No. 18, Marc. CP/1

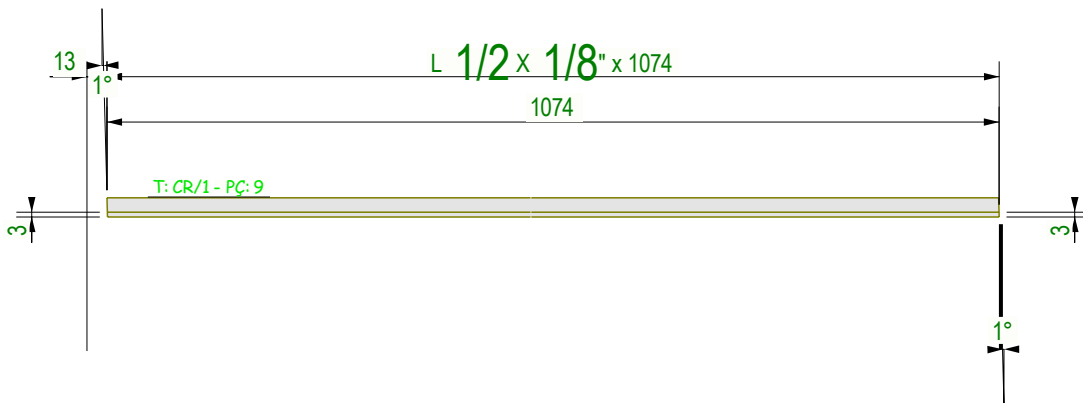

No. 1, Marc. CR/1

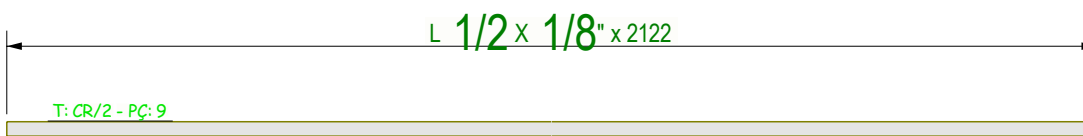

No. 23, Marc. CR/2

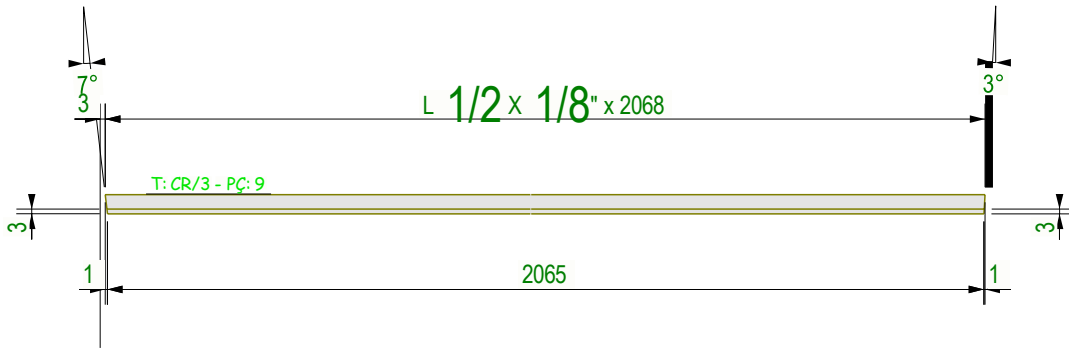

No. 2, Marc. CR/3

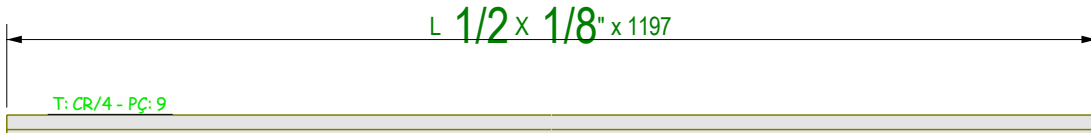

No. 23, Marc. CR/4

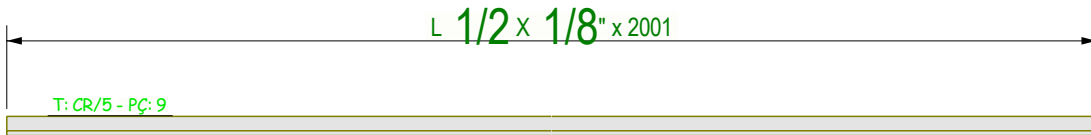

No. 45, Marc. CR/5

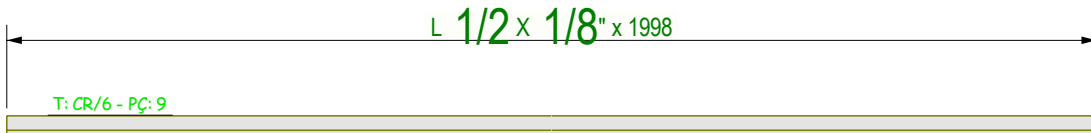

No. 26, Marc. CR/6

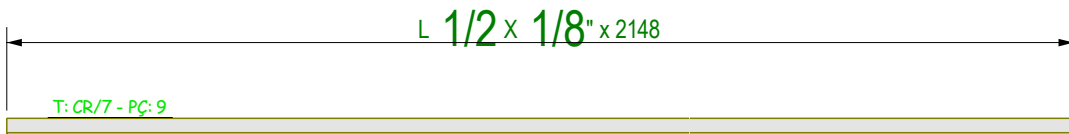

No. 2, Marc. CR/7

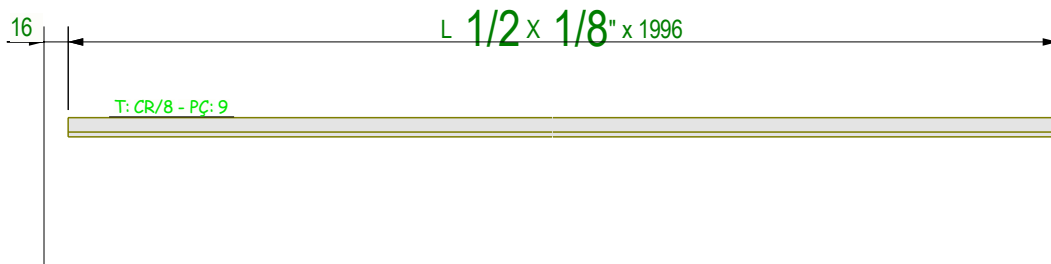

No. 1, Marc. CR/8

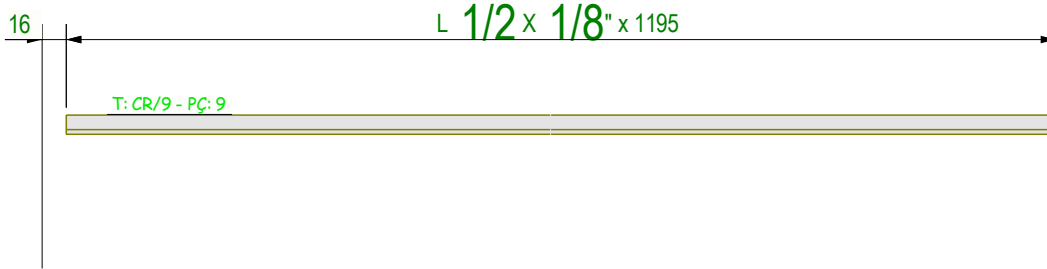

No. 1, Marc. CR/9

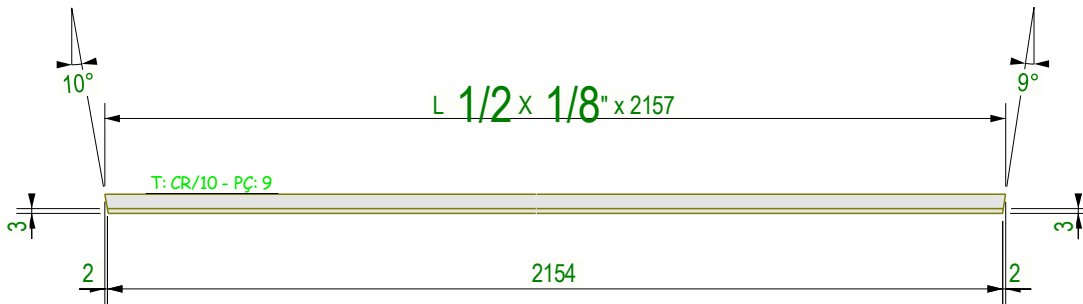

No. 1, Marc. CR/10

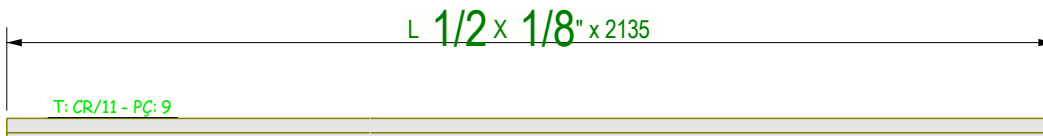

No. 22, Marc. CR/11

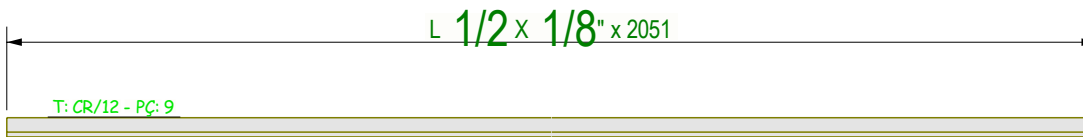

No. 22, Marc. CR/12

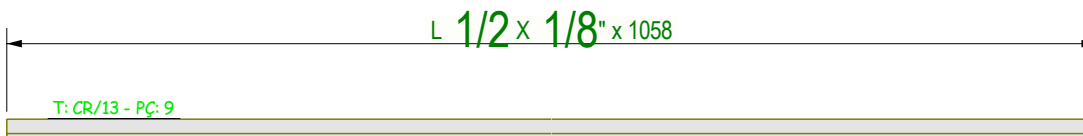

No. 7, Marc. CR/13

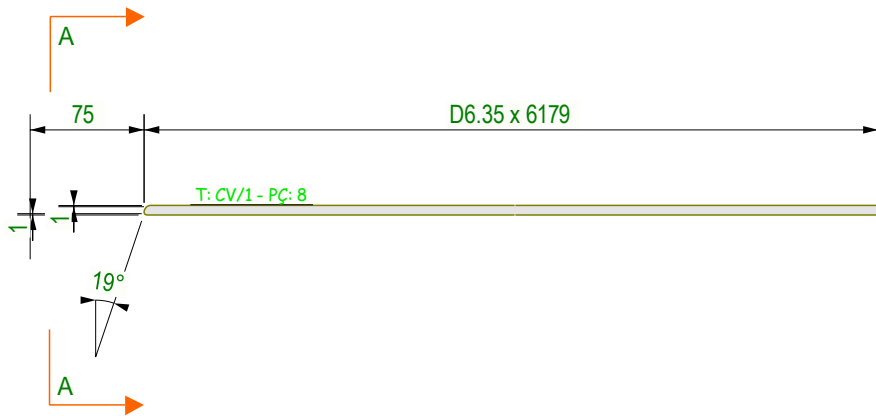
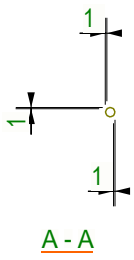
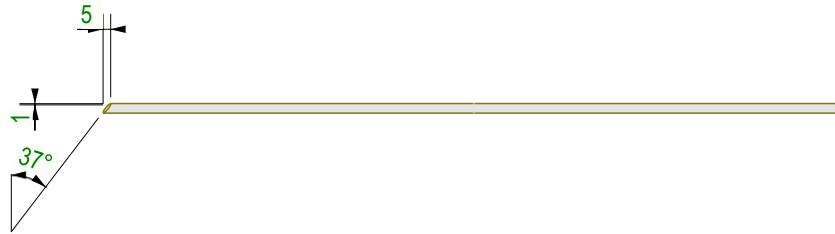

No. 8, Marc. CV/1

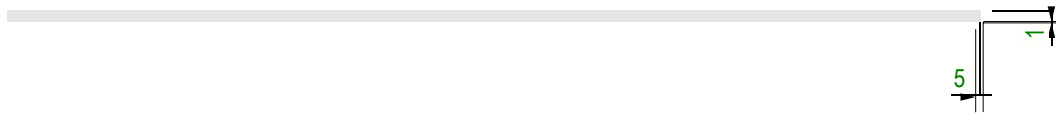
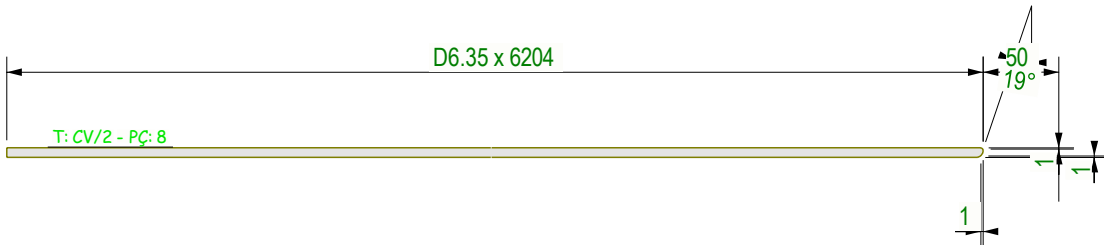

No. 8, Marc. CV/2

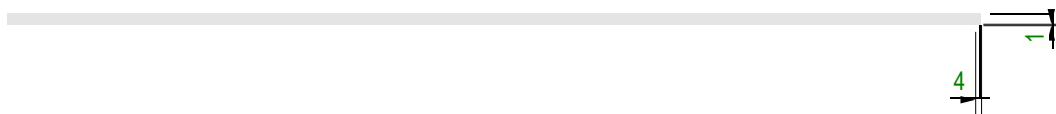
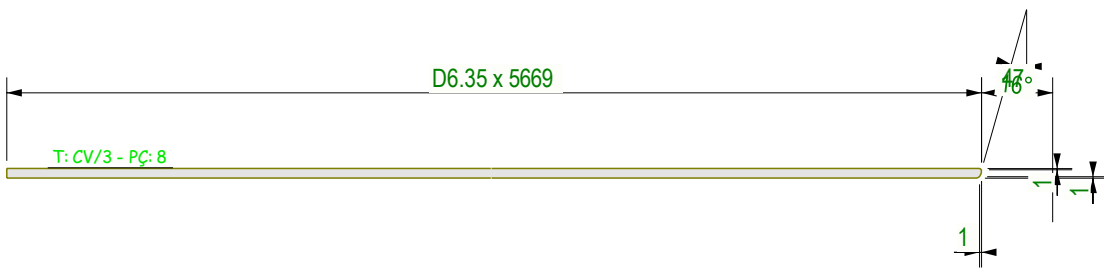

No. 5, Marc. CV/3

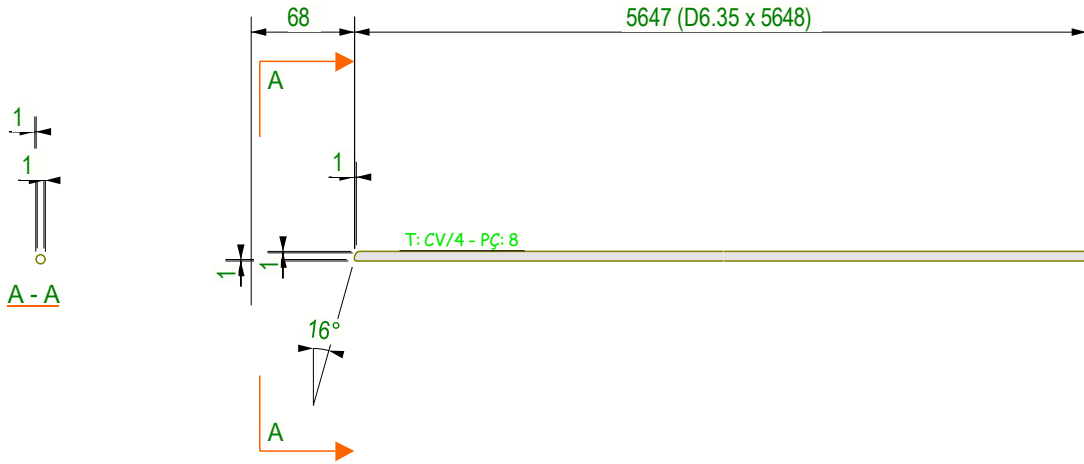
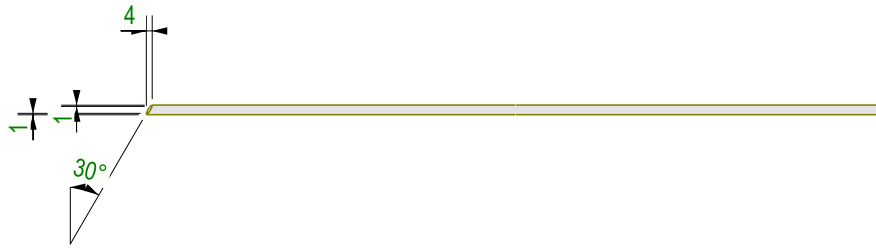

No. 8, Marc. CV/4

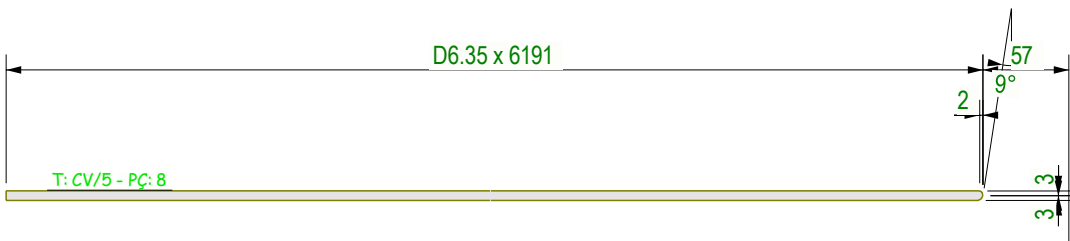

No. 8, Marc. CV/5

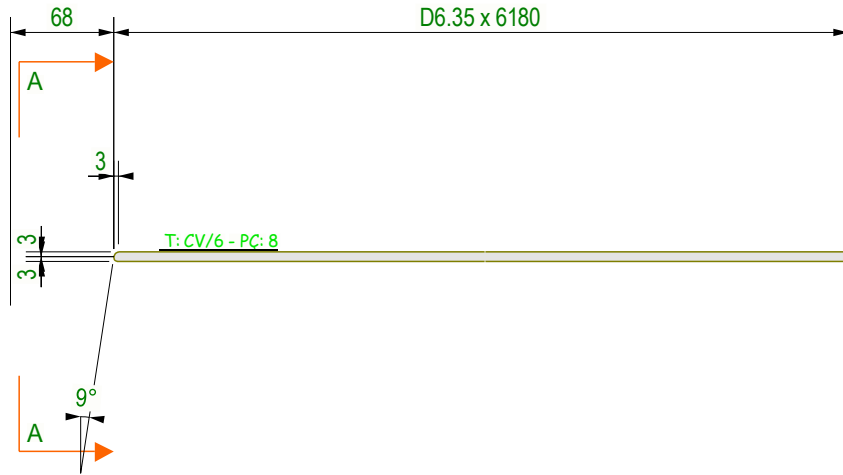
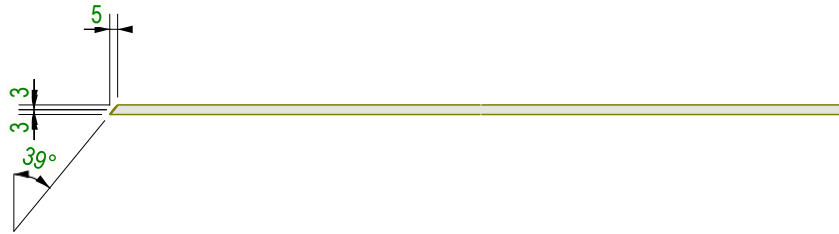

No. 8, Marc. CV/6

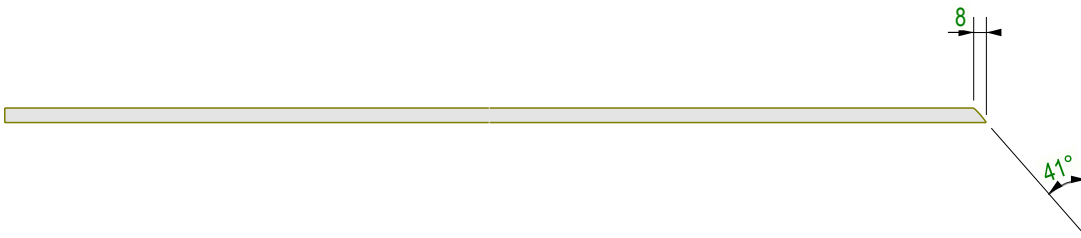

No. 6, Marc. CV/7

T: CV/8 - PÇ: 10

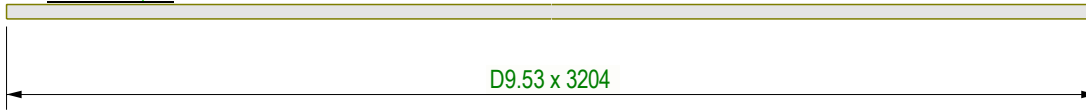

D9.53 x 3204

No. 14, Marc. CV/8

D9.53 x 3153

T: CV/9 - PÇ: 10

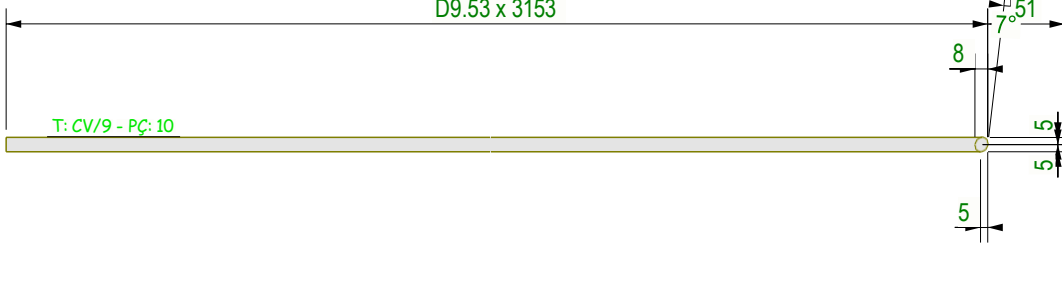

No. 6, Marc. CV/9



D6.35 x 5658

T: CV/10 - PÇ: 8

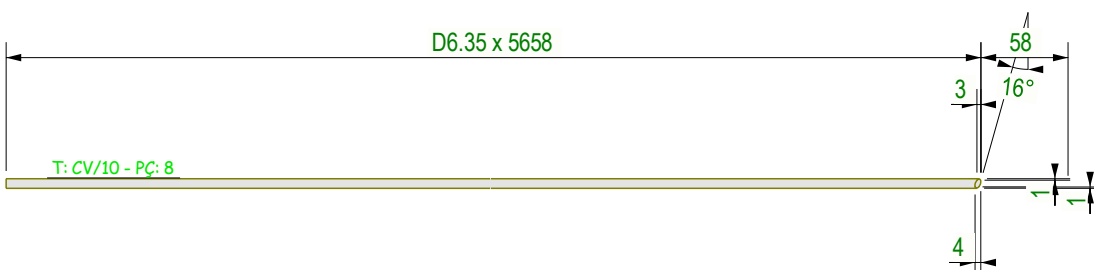

No. 3, Marc. CV/10

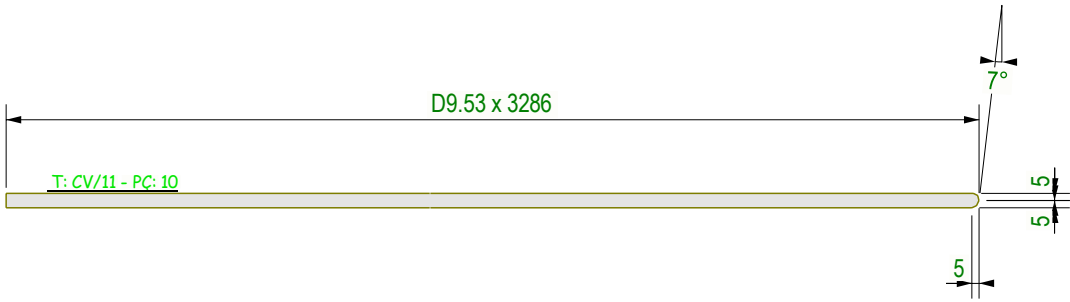
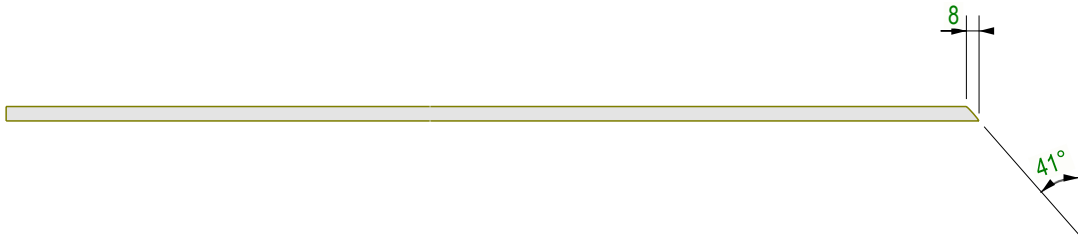

No. 1, Marc. CV/11

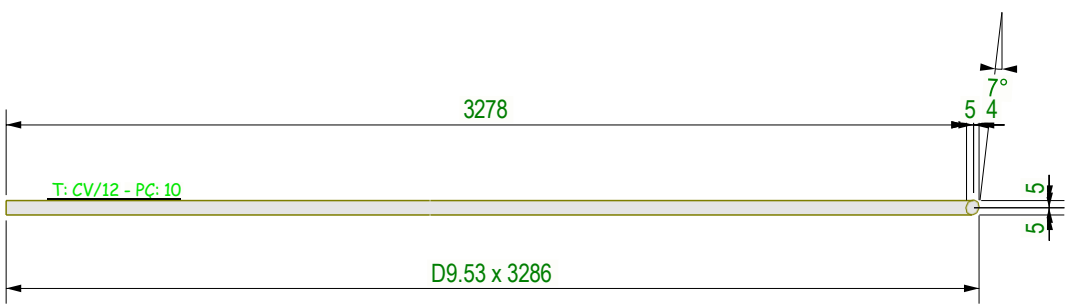

No. 1, Marc. CV/12

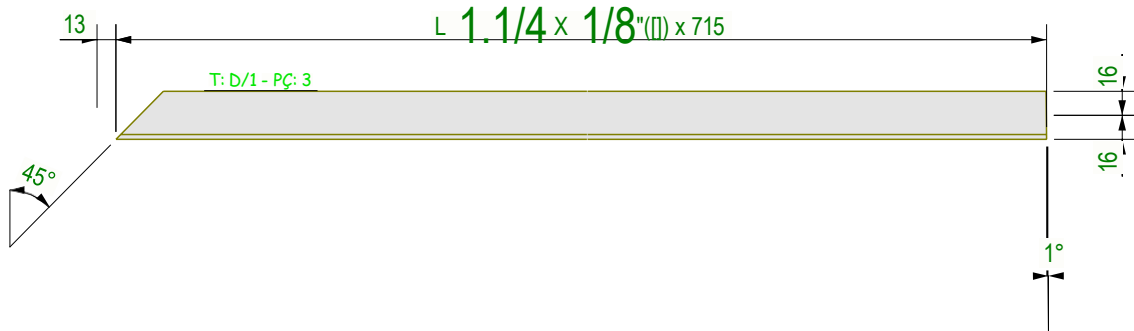
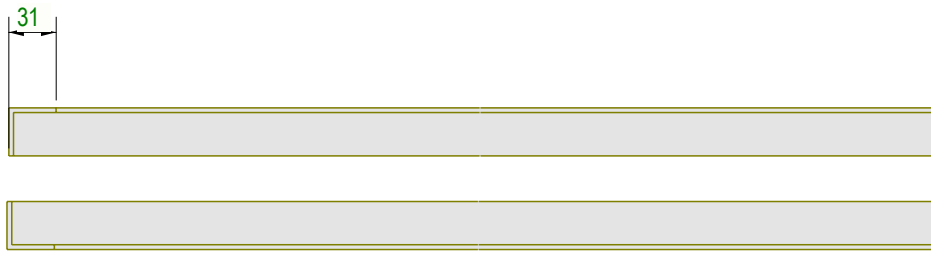

No. 9, Marc. D/1

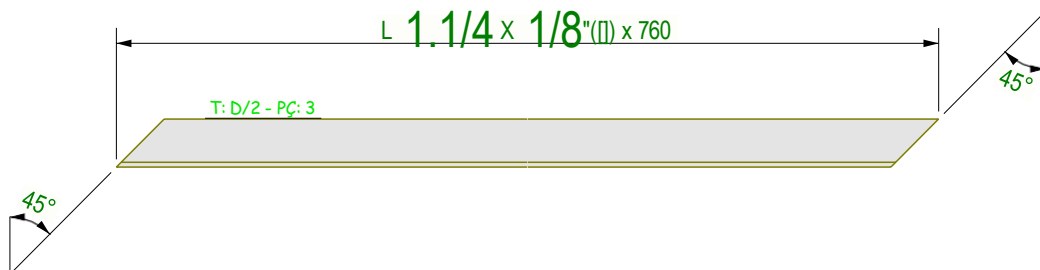
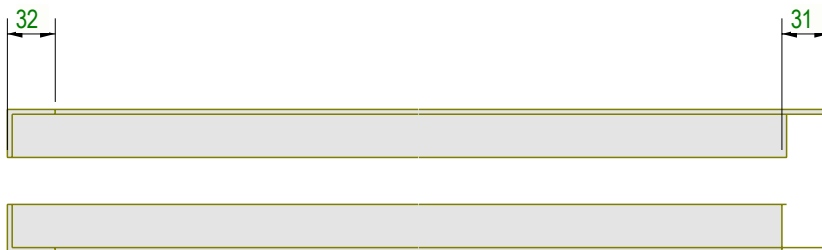

No. 9, Marc. D/2

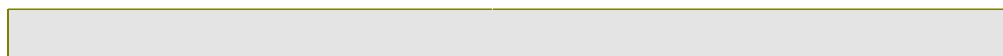
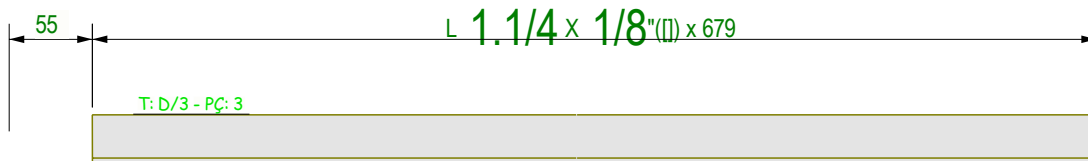

No. 18, Marc. D/3

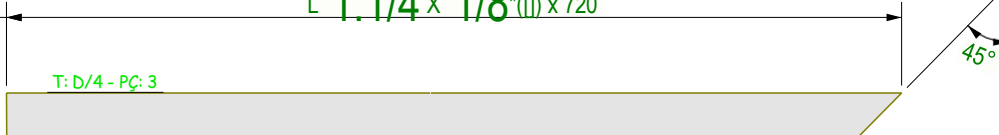
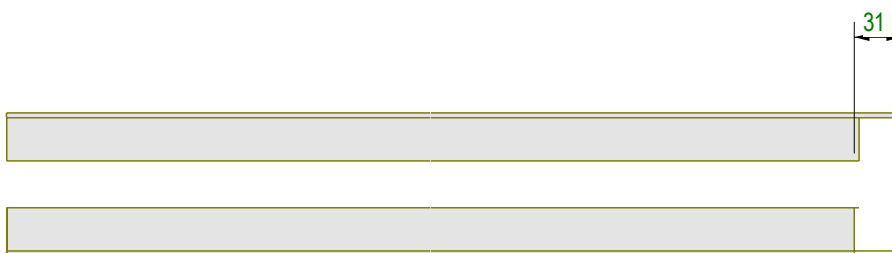

No. 9, Marc. D/4

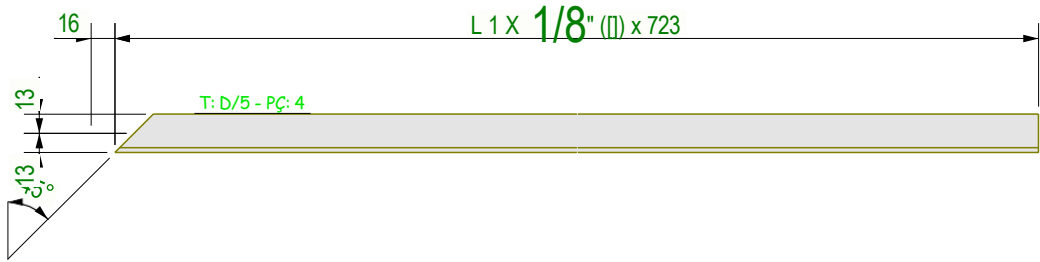
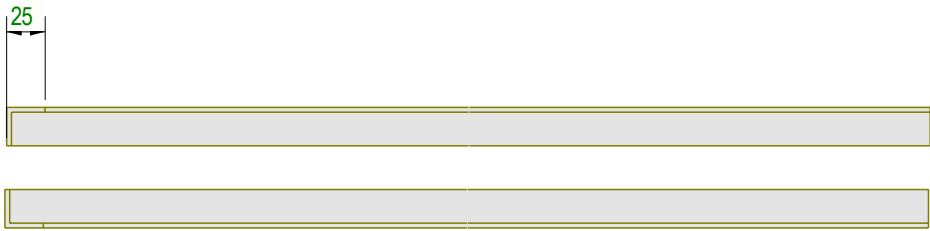

No. 9, Marc. D/5

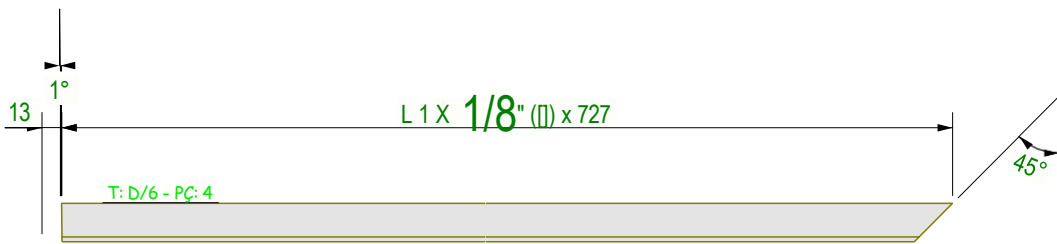
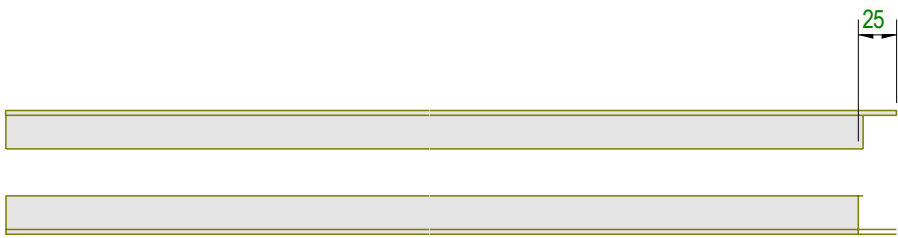

No. 9, Marc. D/6

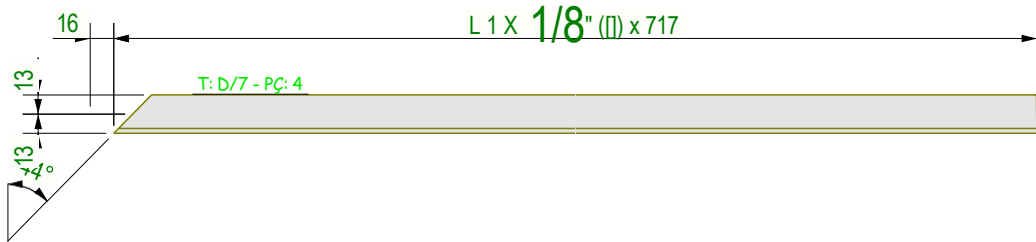
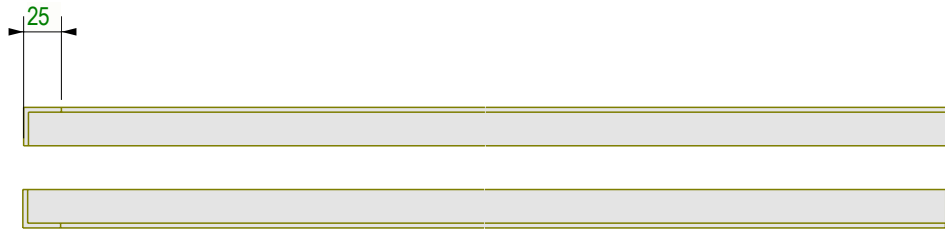

No. 36, Marc. D/7

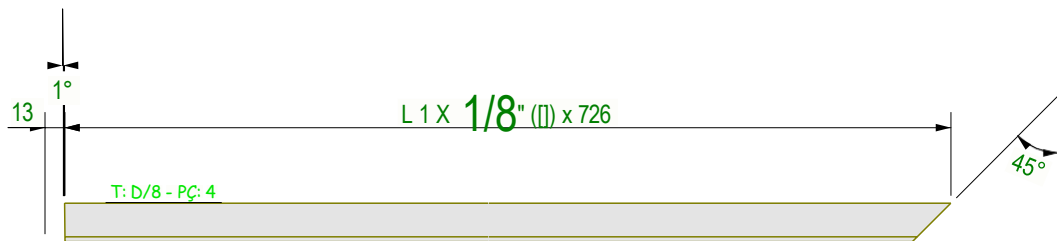
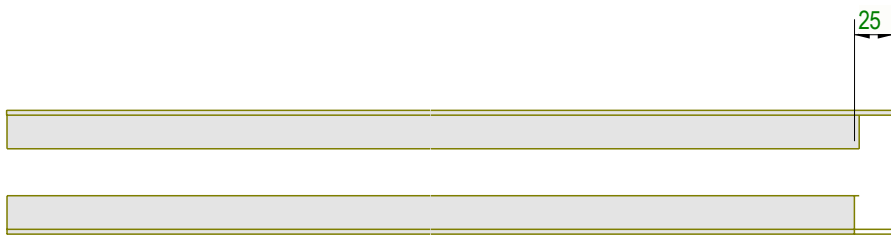

No. 9, Marc. D/8

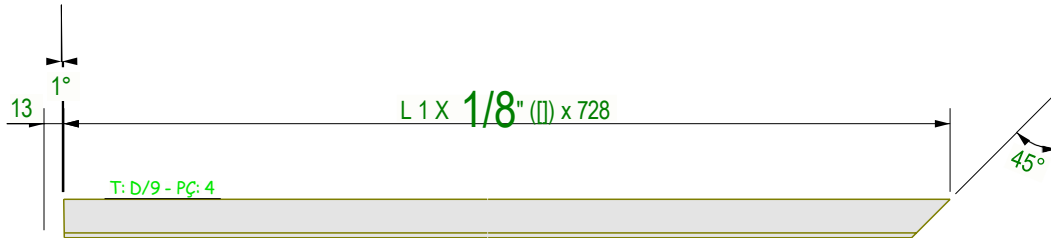
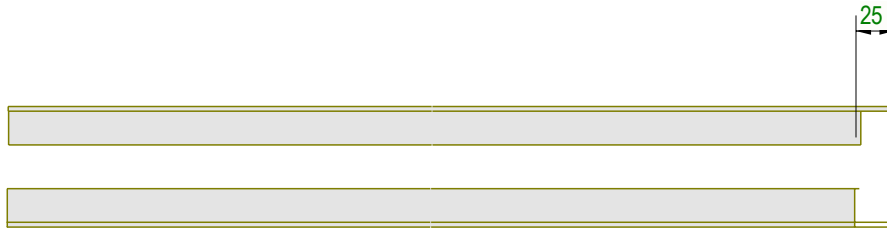

No. 18, Marc. D/9

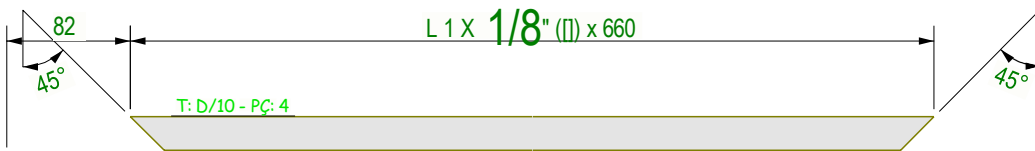
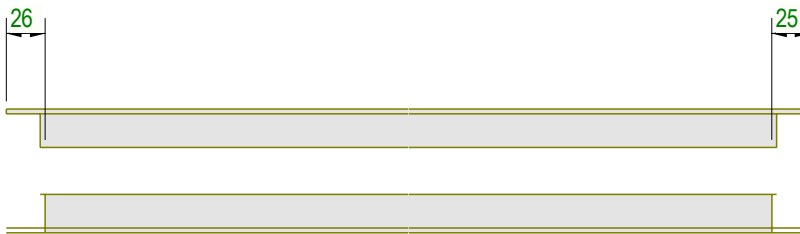

No. 18, Marc. D/10

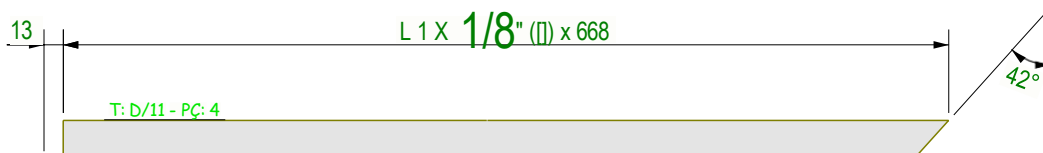
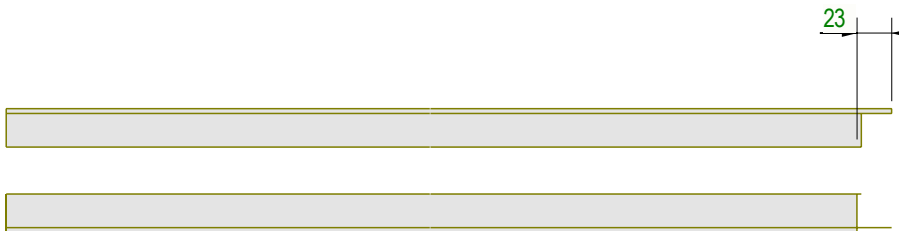

No. 9, Marc. D/11

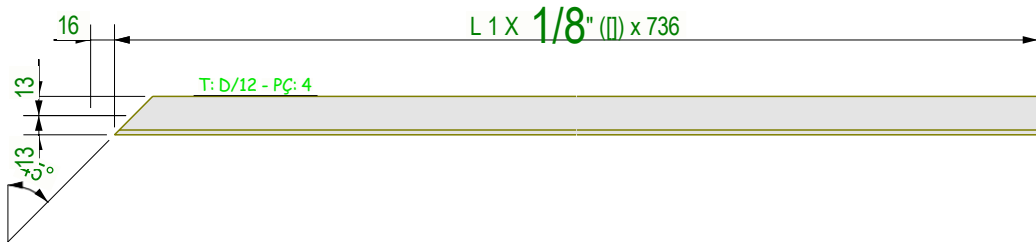
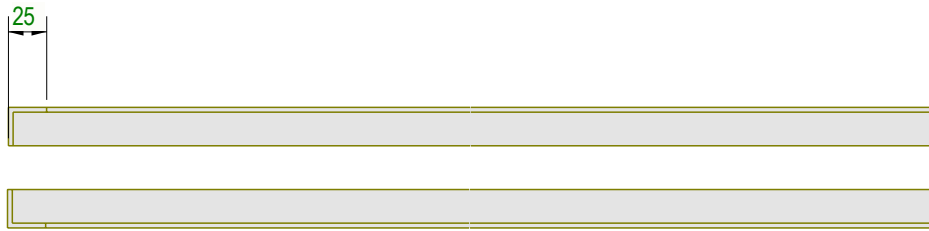

No. 9, Marc. D/12

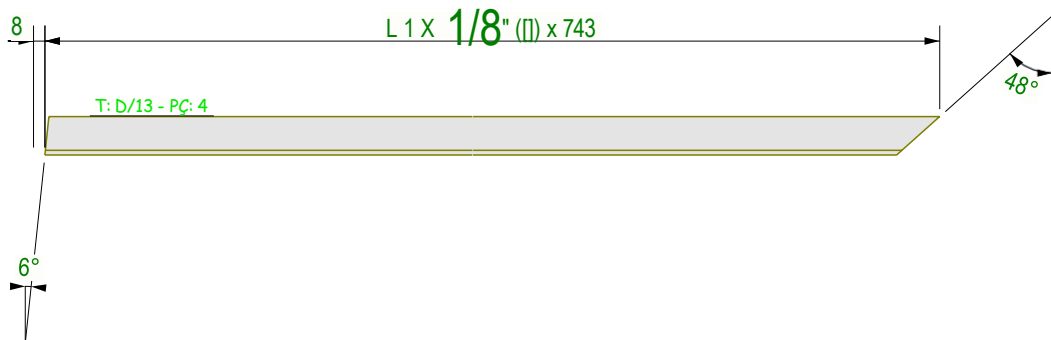
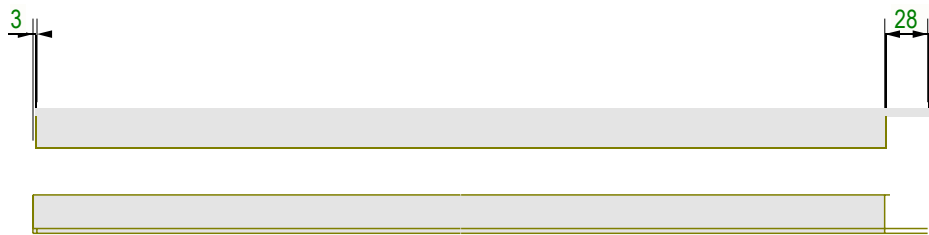

No. 9, Marc. D/13

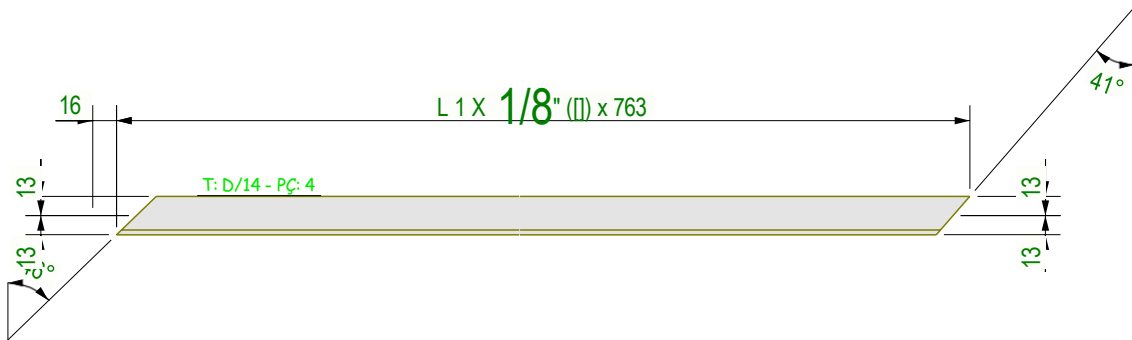
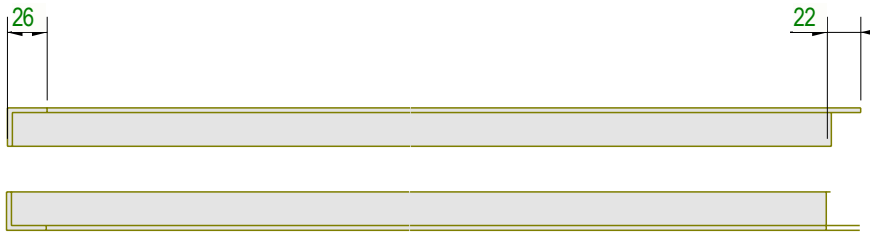

No. 9, Marc. D/14

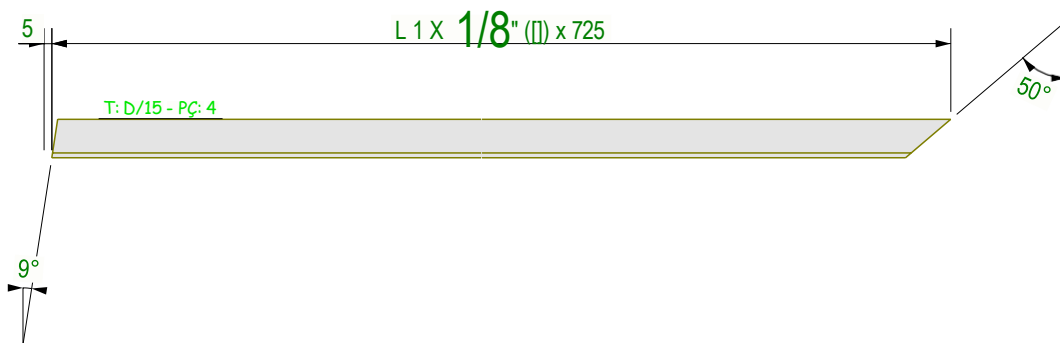
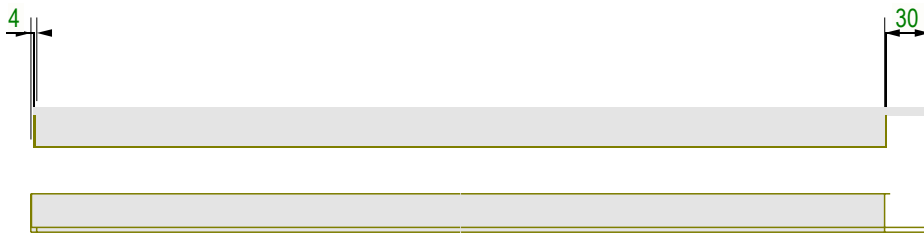

No. 9, Marc. D/15

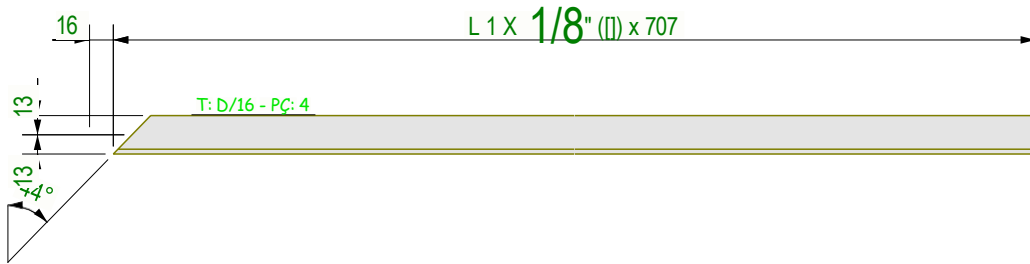
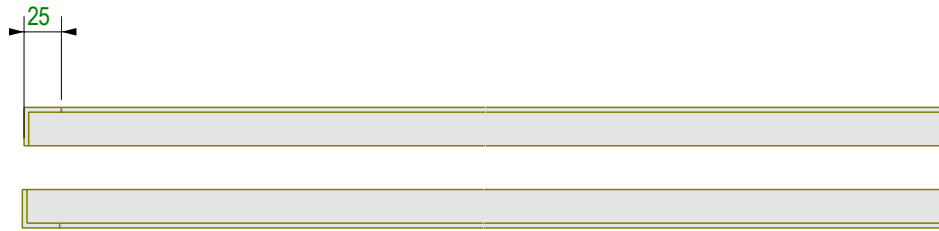

No. 9. Marc. D/16

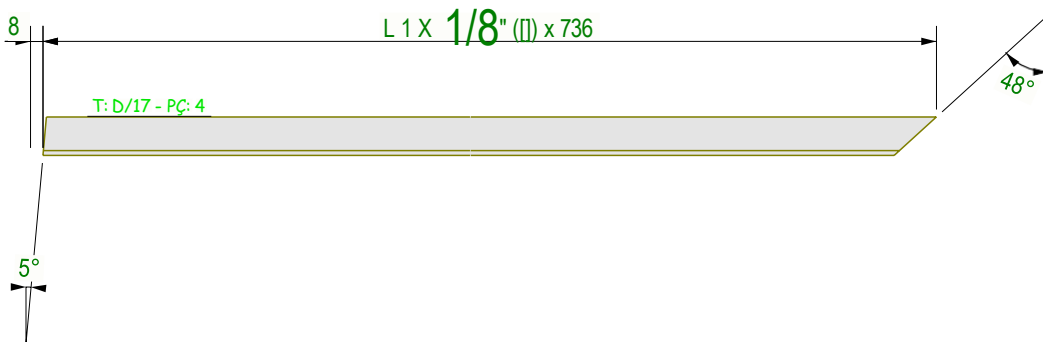
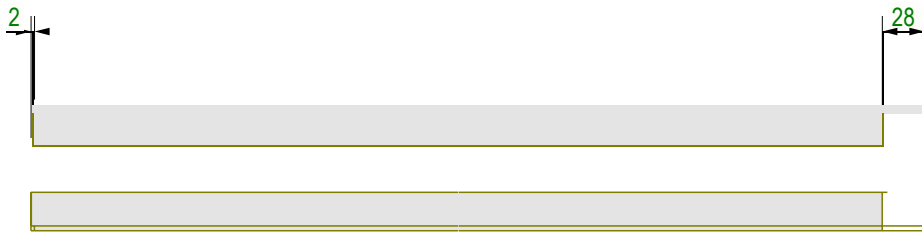

No. 9. Marc. D/17

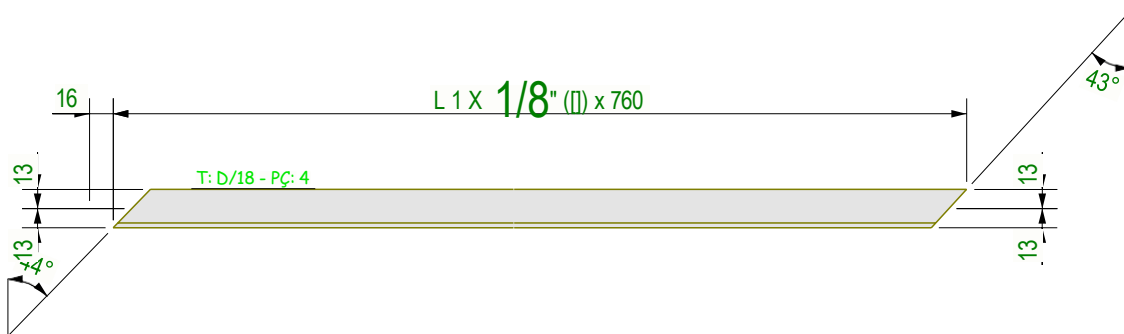
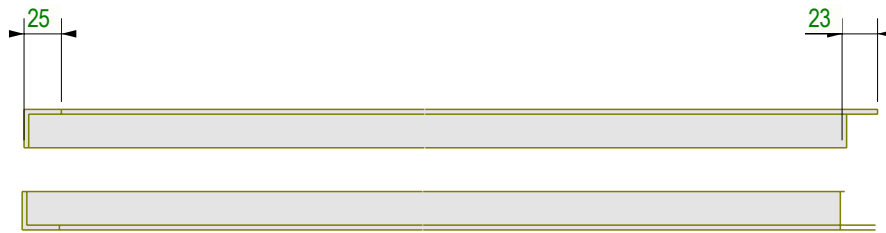

No. 9, Marc. D/18

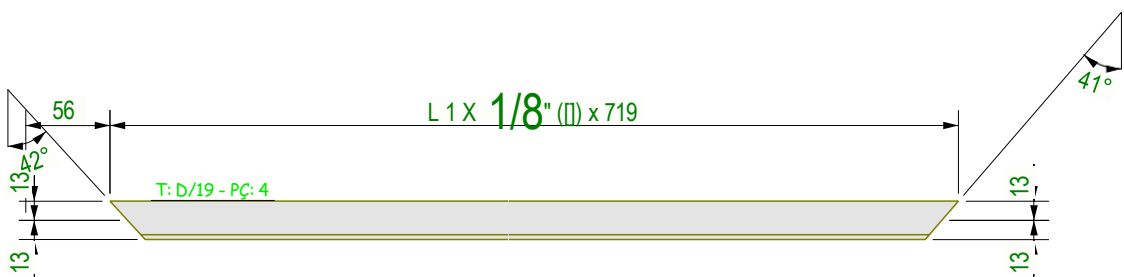
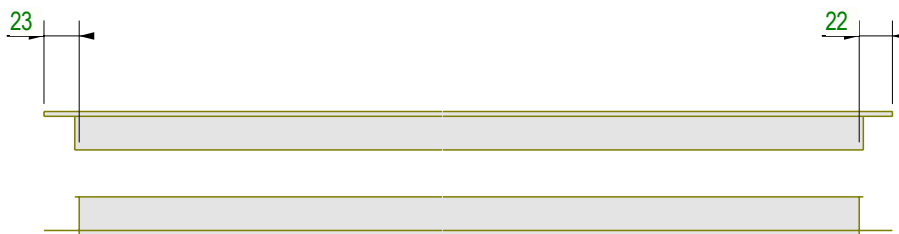

No. 9, Marc. D/19

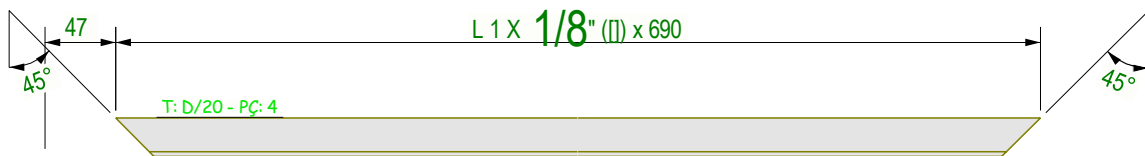
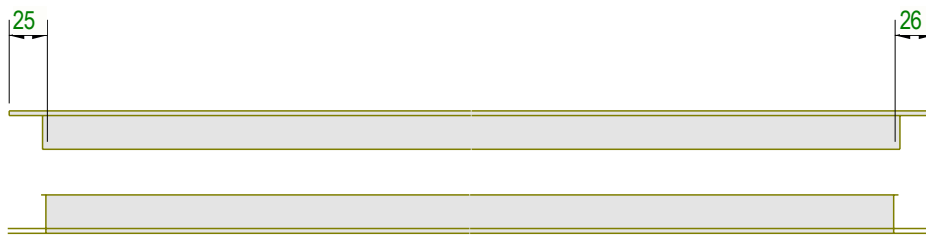

No. 18, Marc. D/20

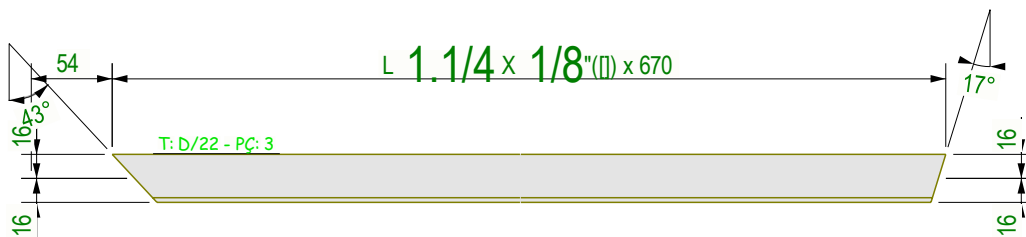
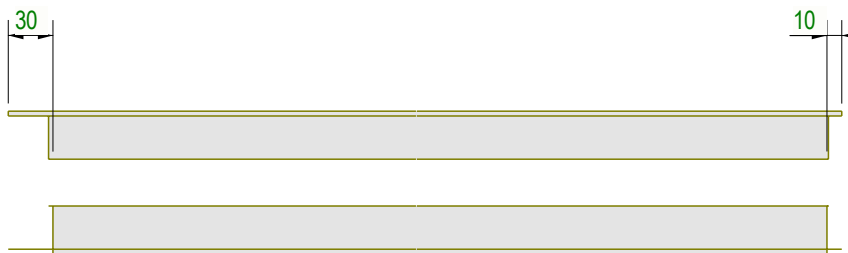

No. 9, Marc. D/22

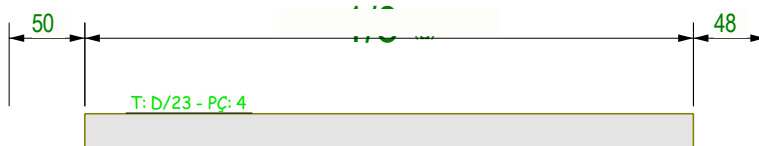

No. 18, Marc. D/23

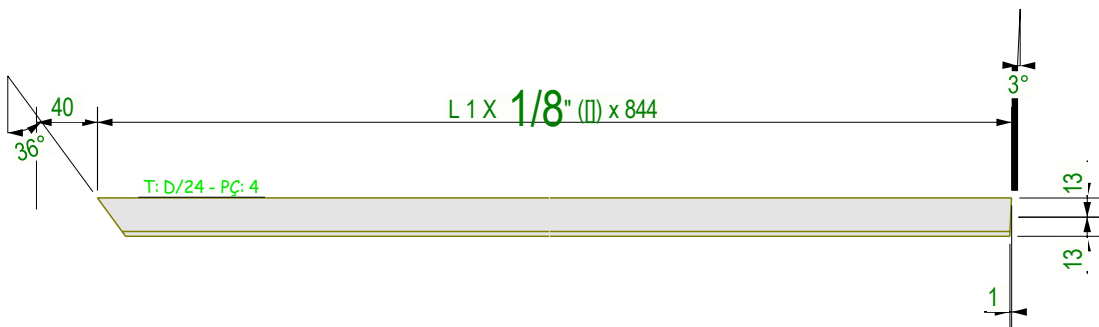
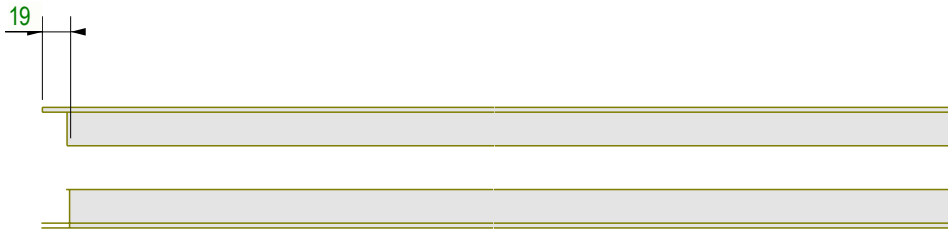

No. 9, Marc. D/24

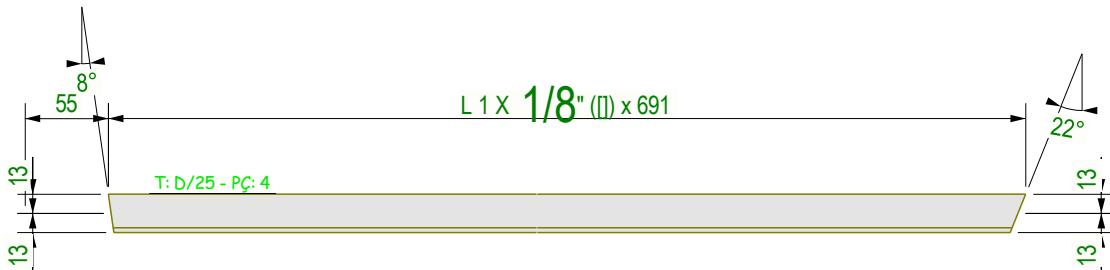
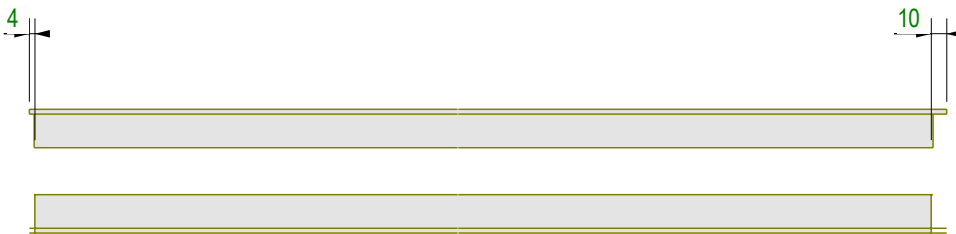

No. 9, Marc. D/25

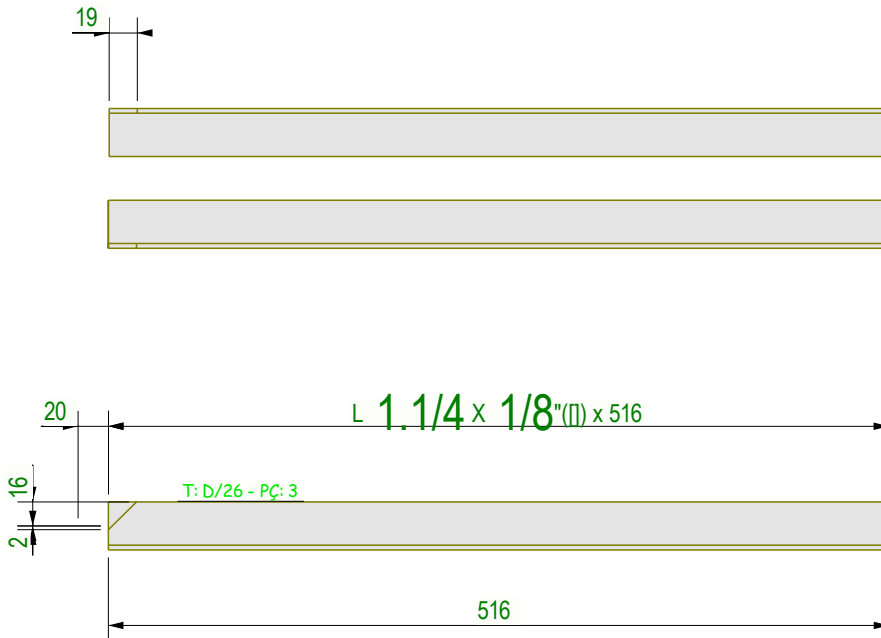

No. 9, Marc. D/26

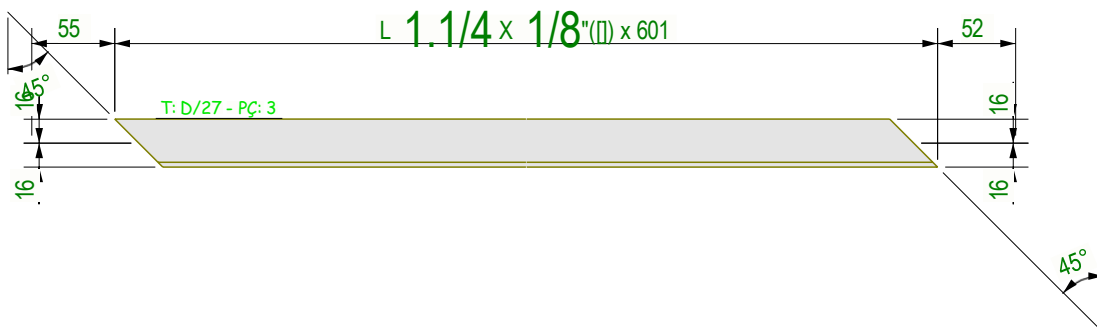
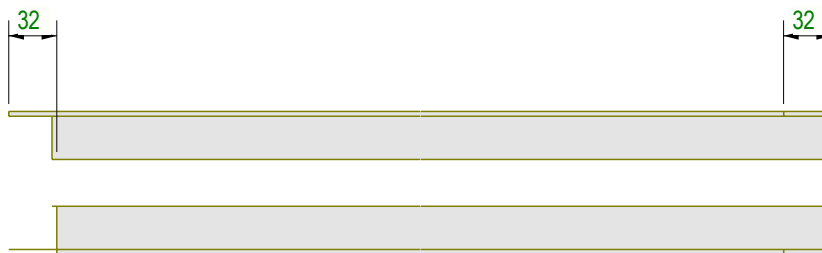

No. 63, Marc. D/27

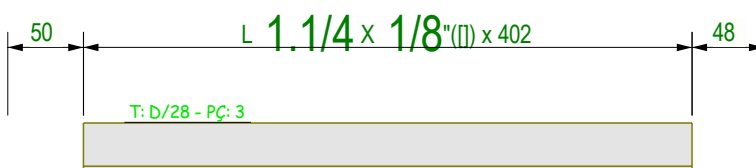

No. 18, Marc. D/28

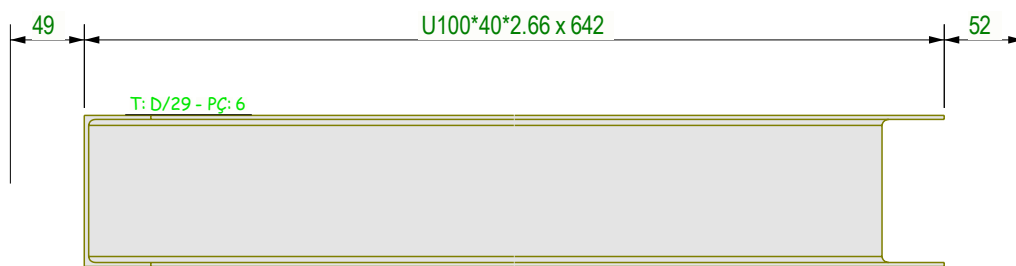
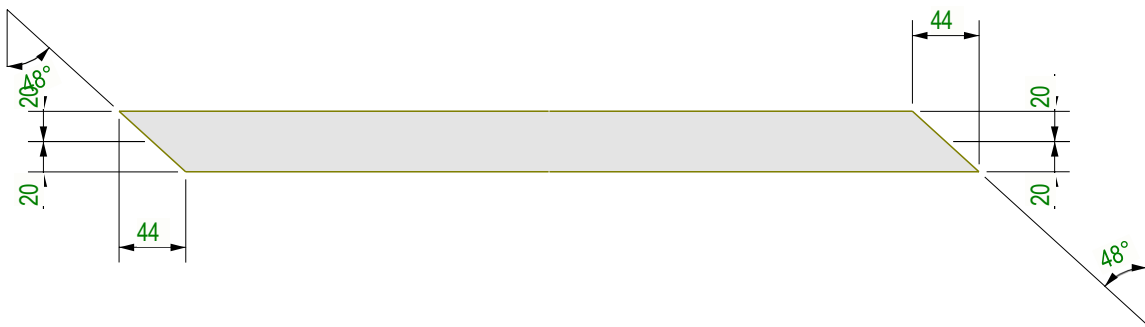

No. 18, Marc. D/29

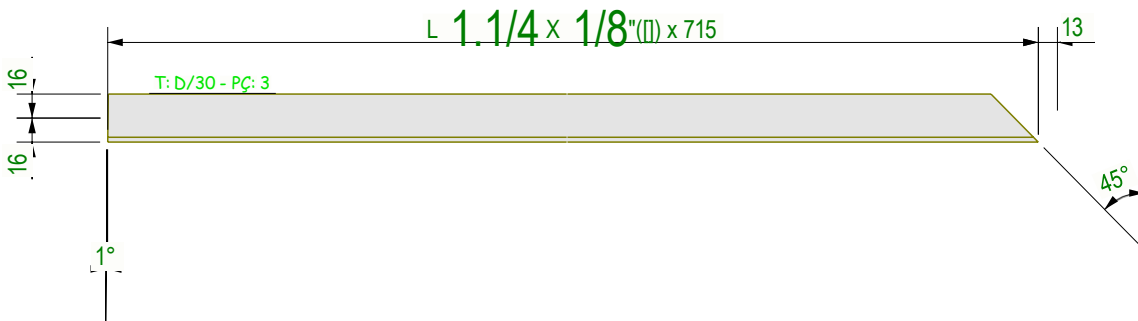
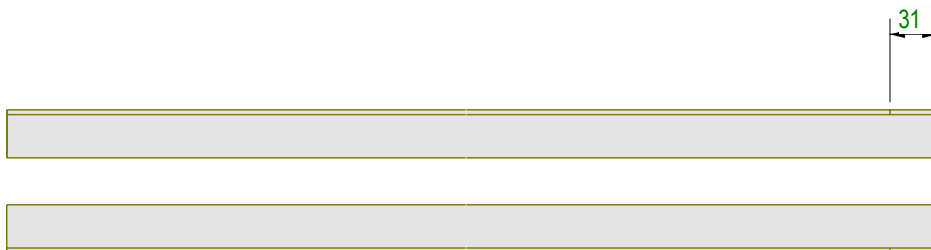

No. 9, Marc. D/30

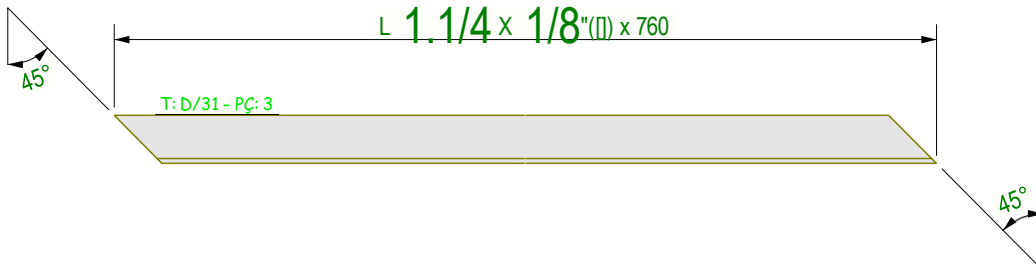
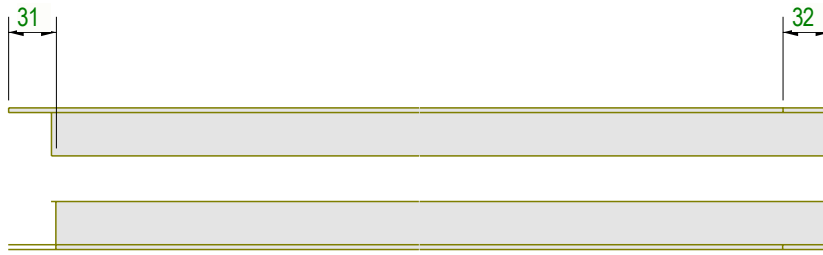

No. 9, Marc. D/31

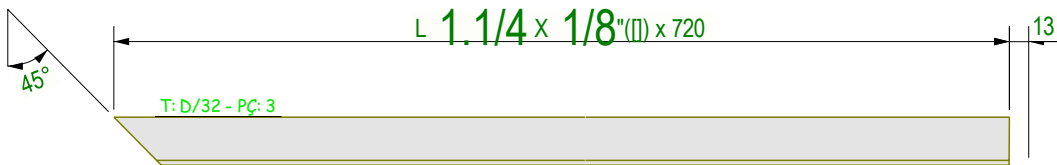
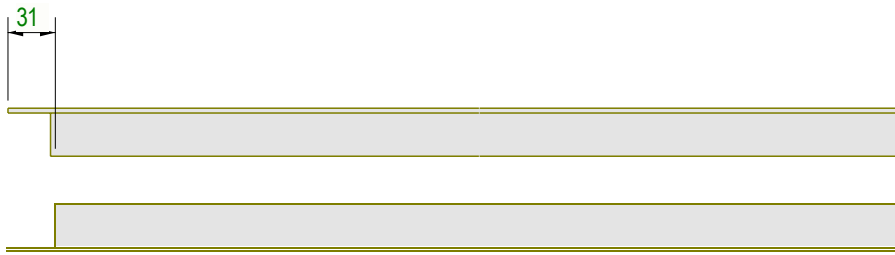

No. 9, Marc. D/32

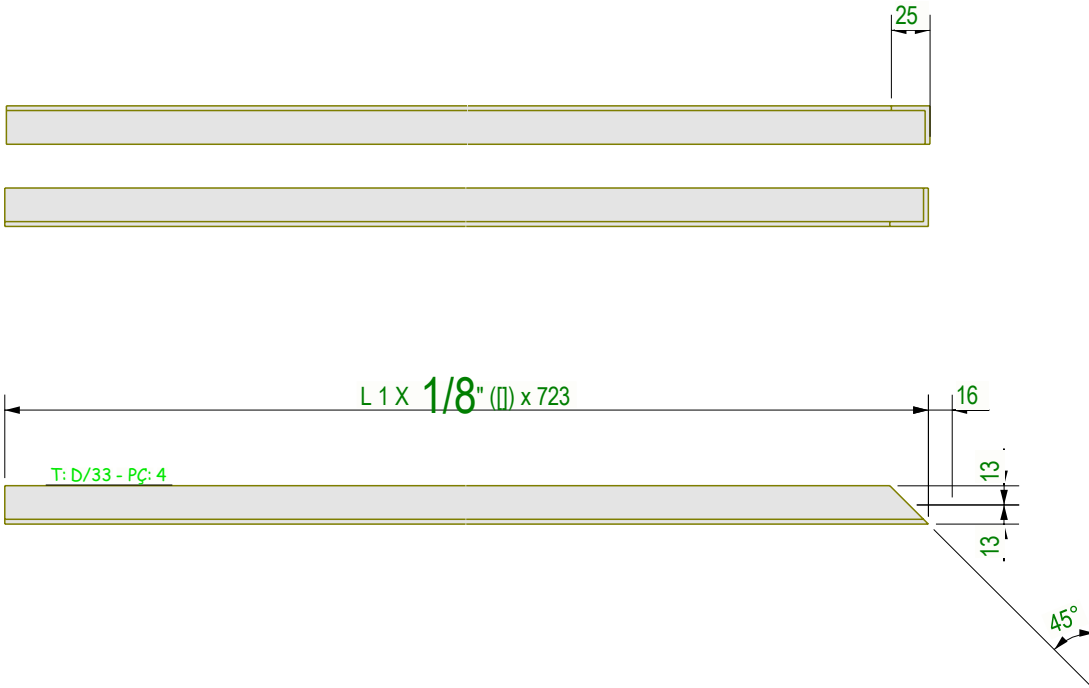

No. 9, Marc. D/33

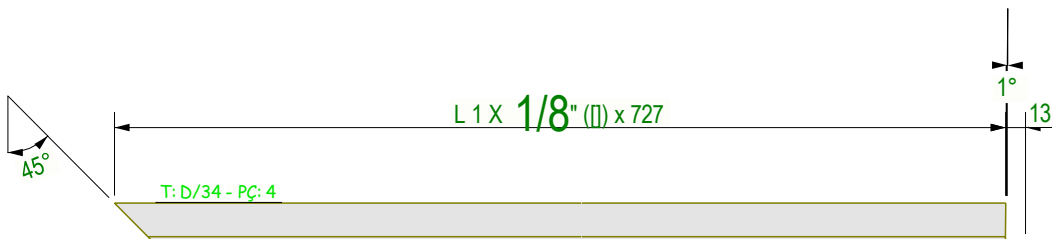

No. 9, Marc. D/34

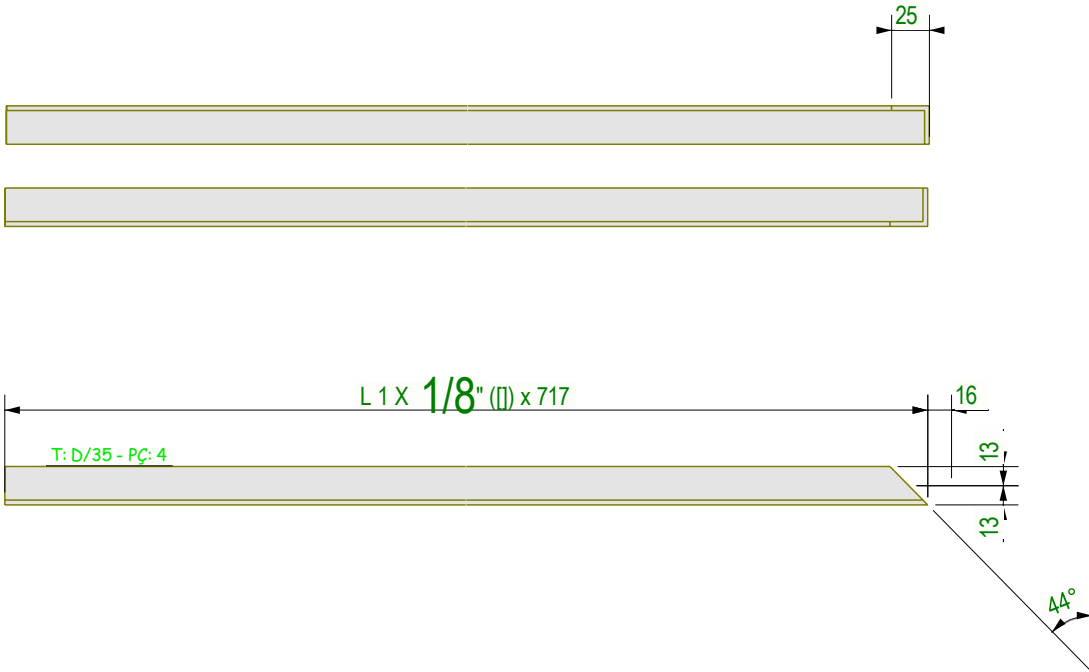

No. 36, Marc. D/35

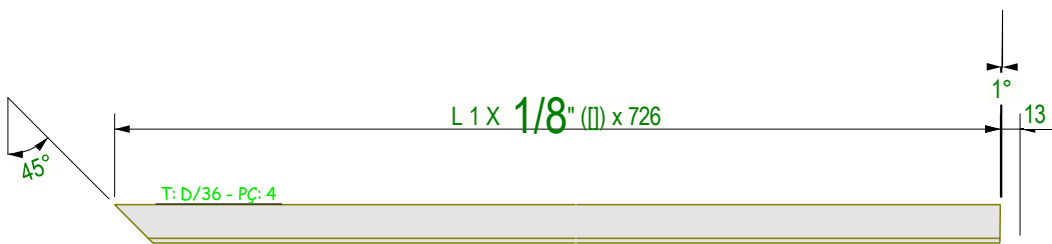
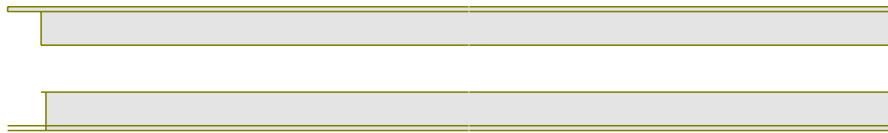

No. 9, Marc. D/36

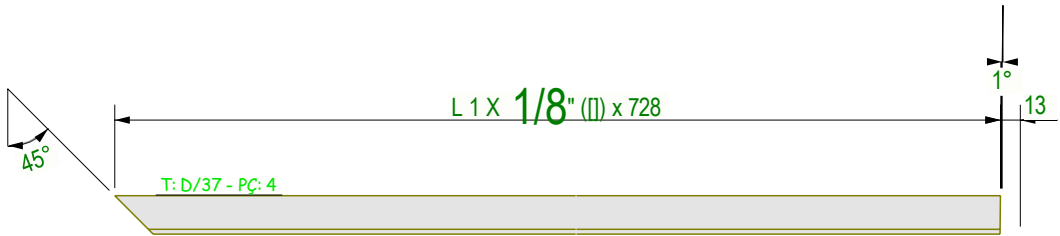
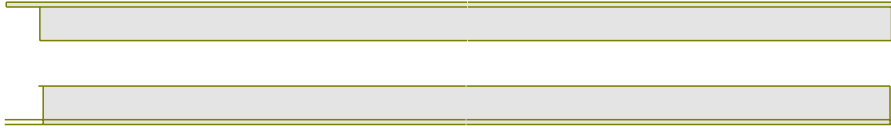

No. 18, Marc. D/37

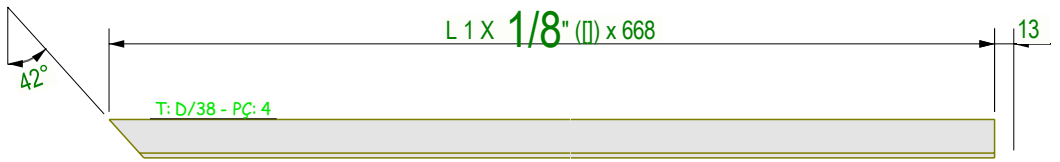
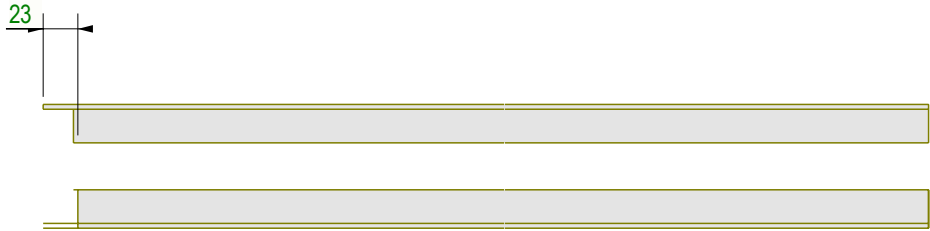

No. 9, Marc. D/38

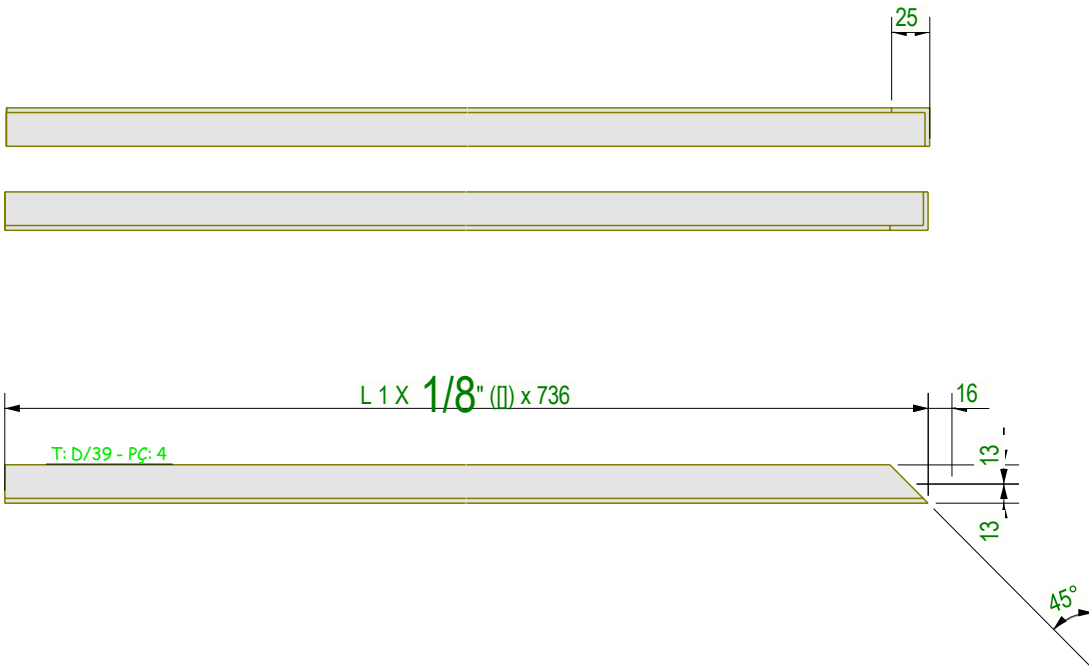

No. 9, Marc. D/39

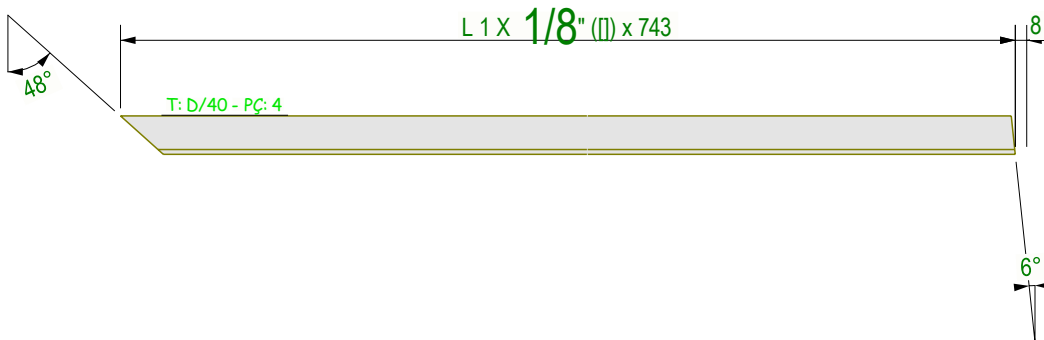
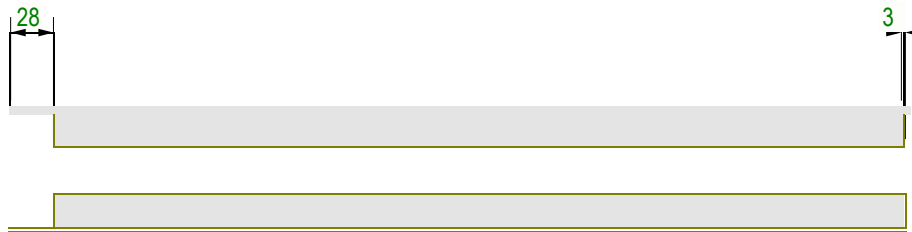

No. 9, Marc. D/40

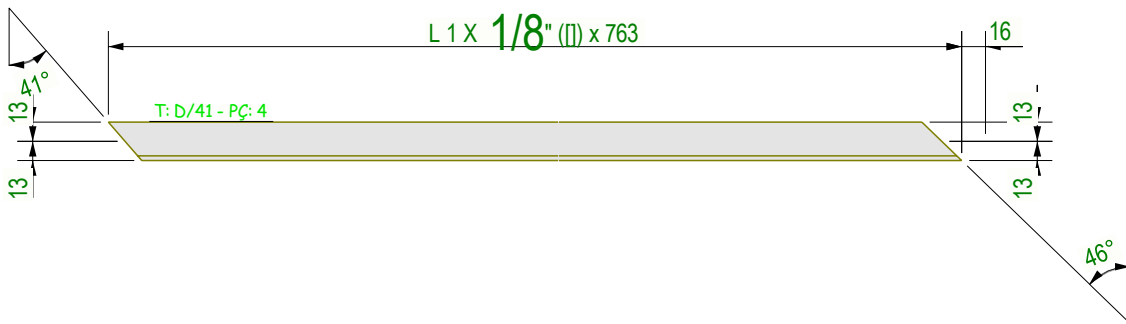
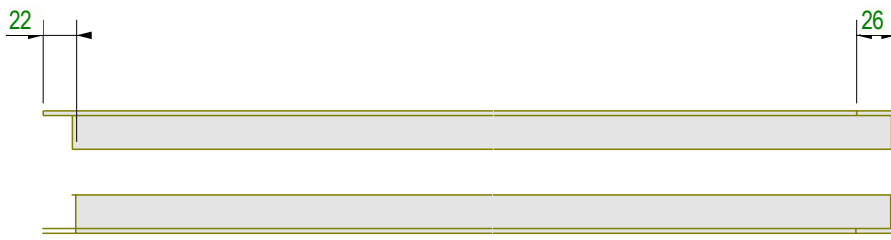

No. 9. Marc. D/41

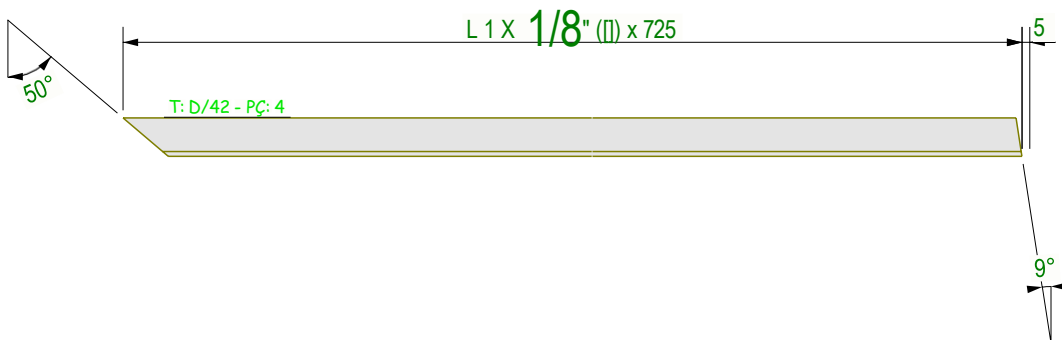
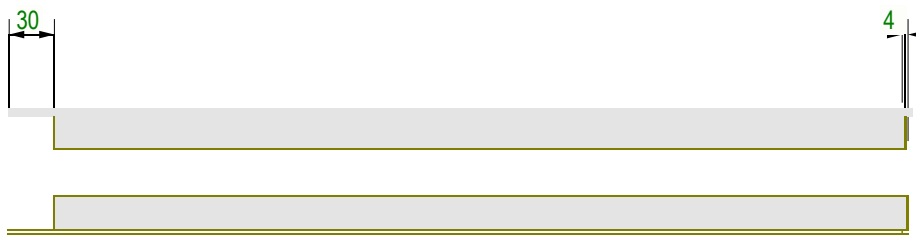

No. 9. Marc. D/42

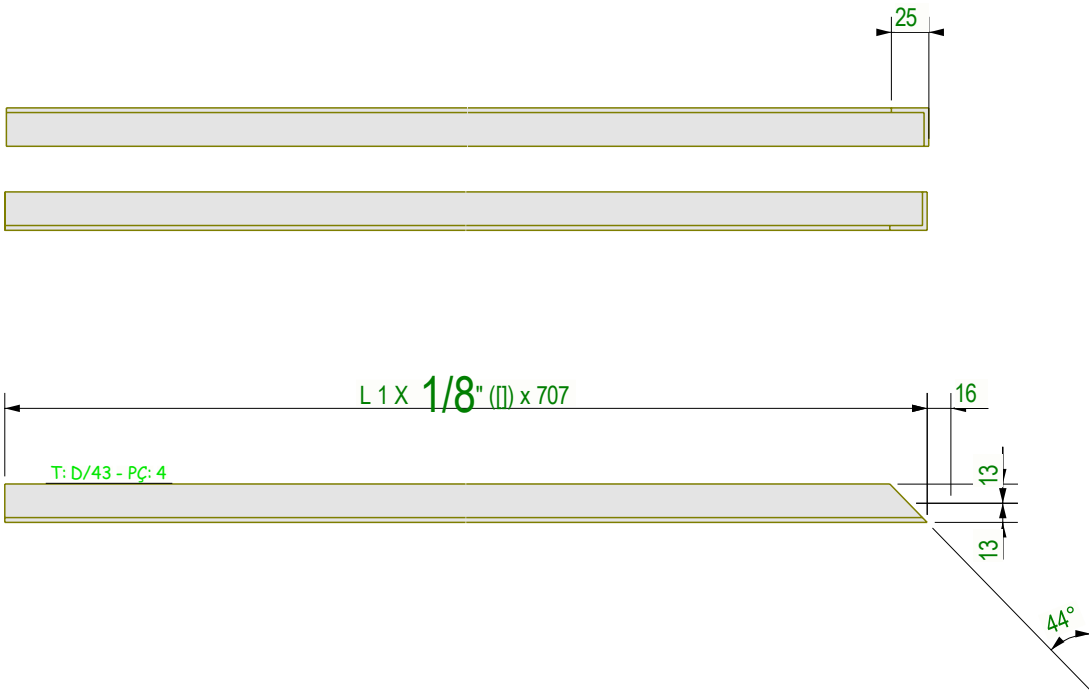

No. 9, Marc. D/43

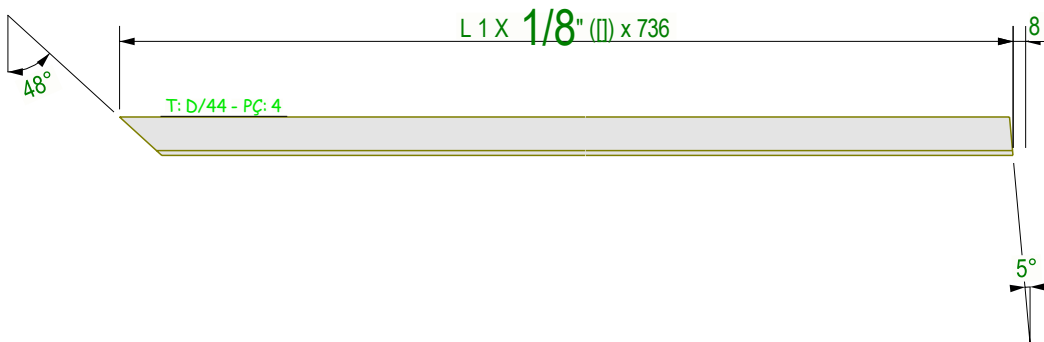
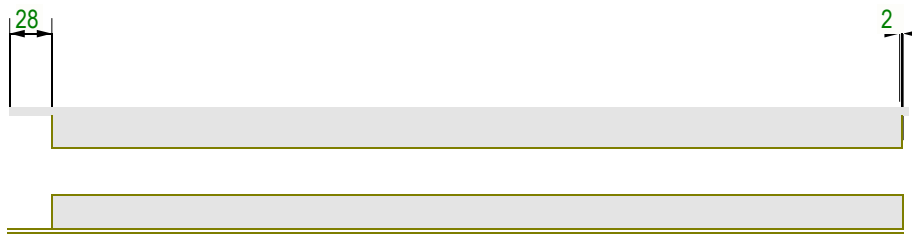

No. 9, Marc. D/44

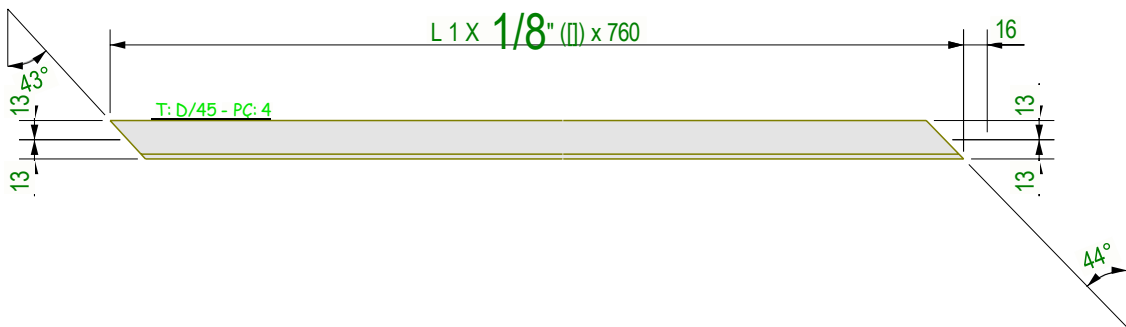
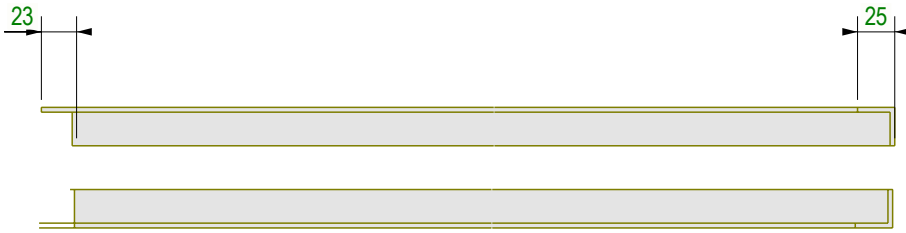

No. 9, Marc. D/45

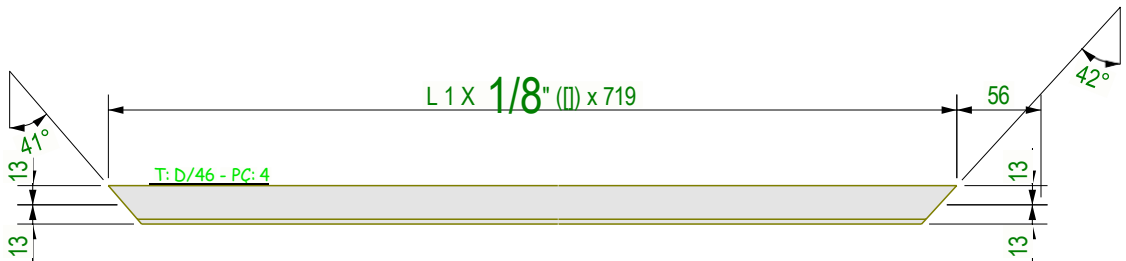
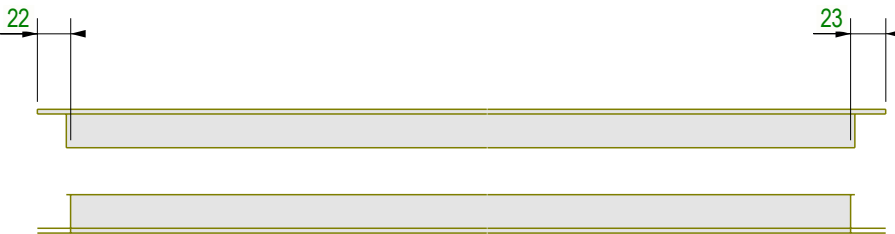

No. 9, Marc. D/46

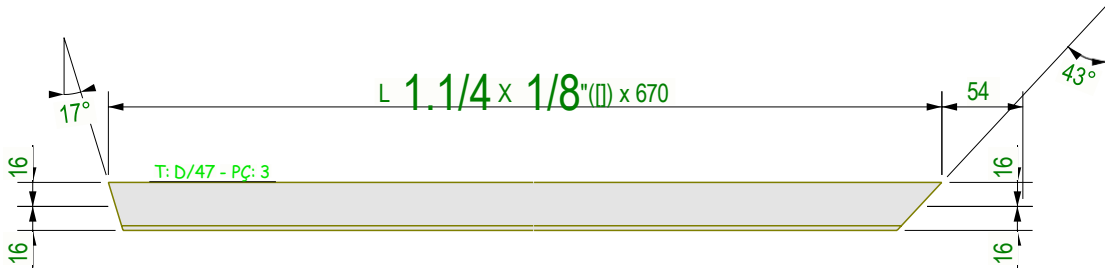
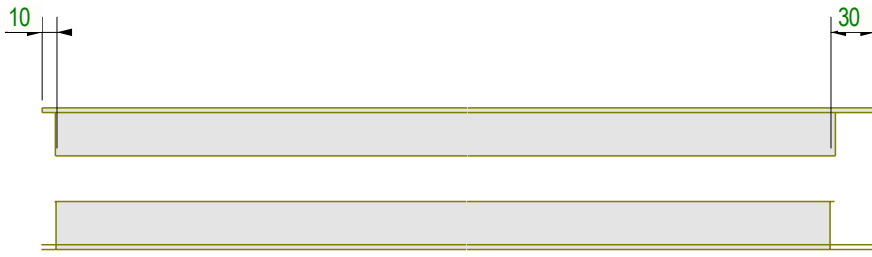

No. 9, Marc. D/47

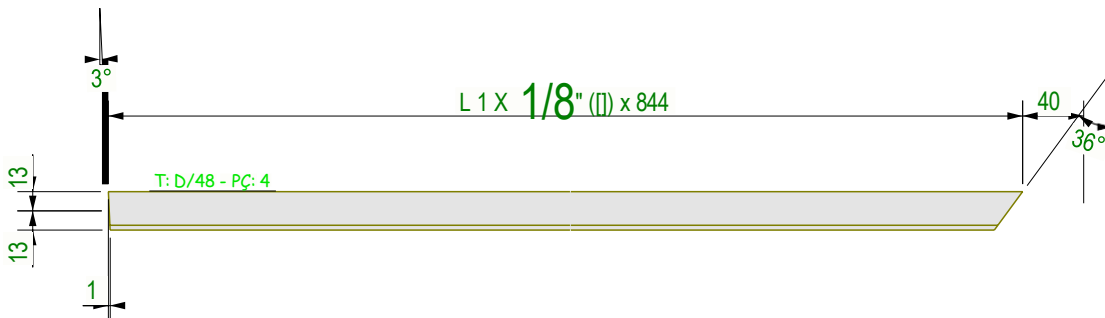
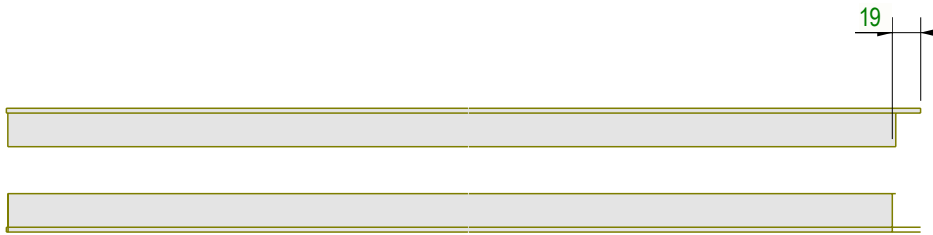

No. 9, Marc. D/48

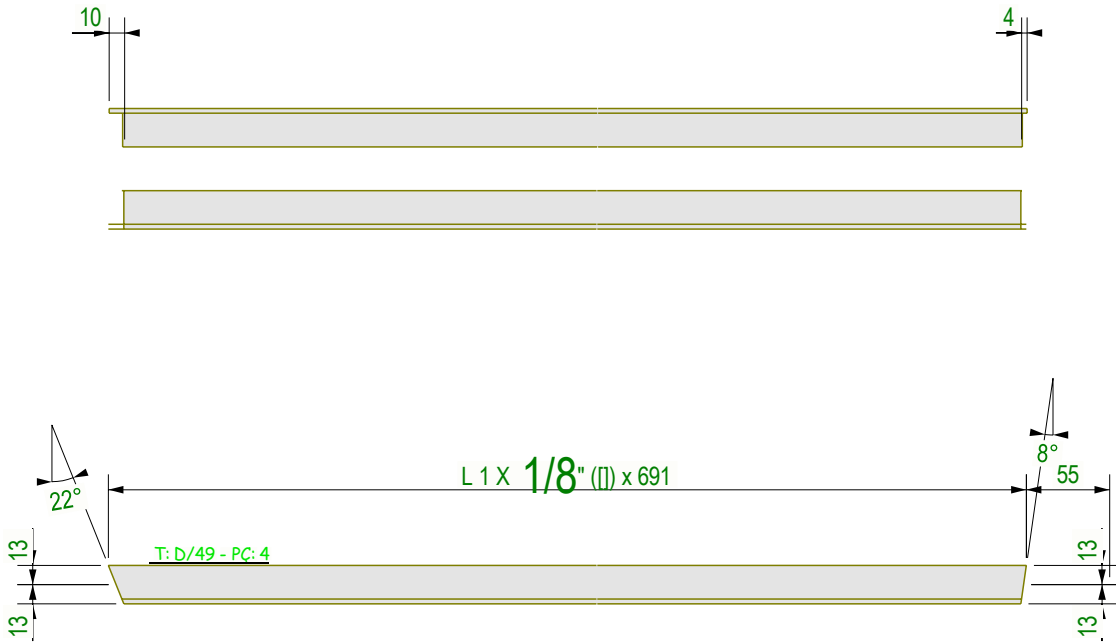

No. 9, Marc. D/49

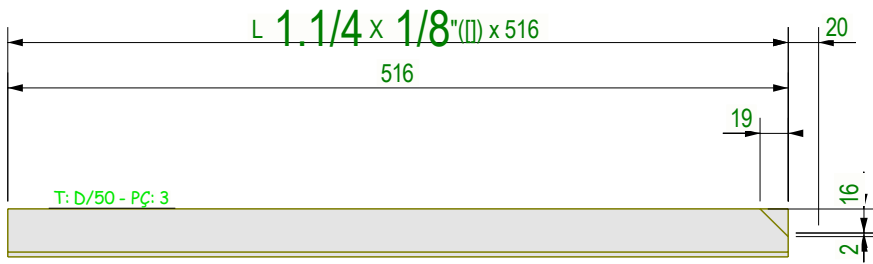

No. 9, Marc. D/50

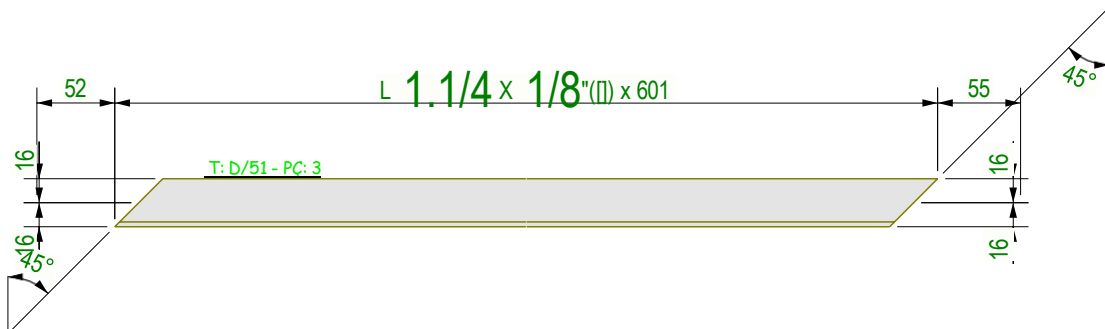
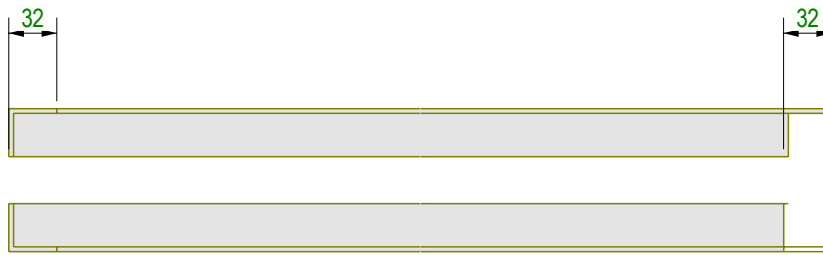

No. 63, Marc. D/51

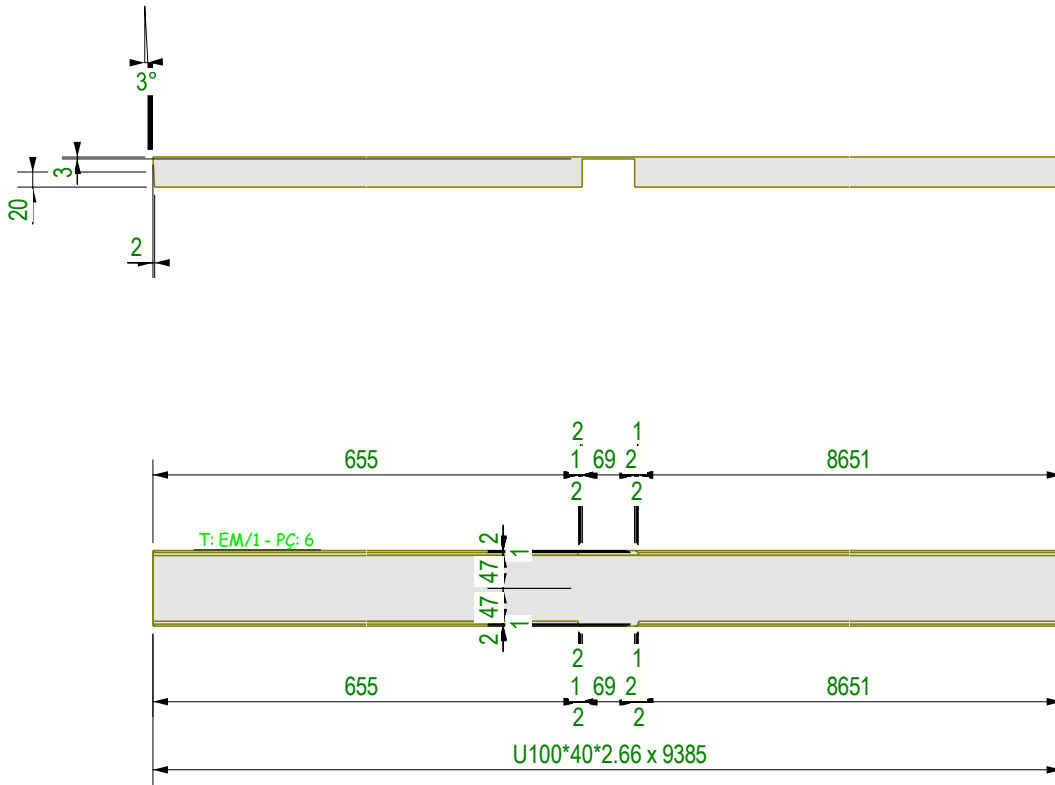

No. 18. Marc. EM/1

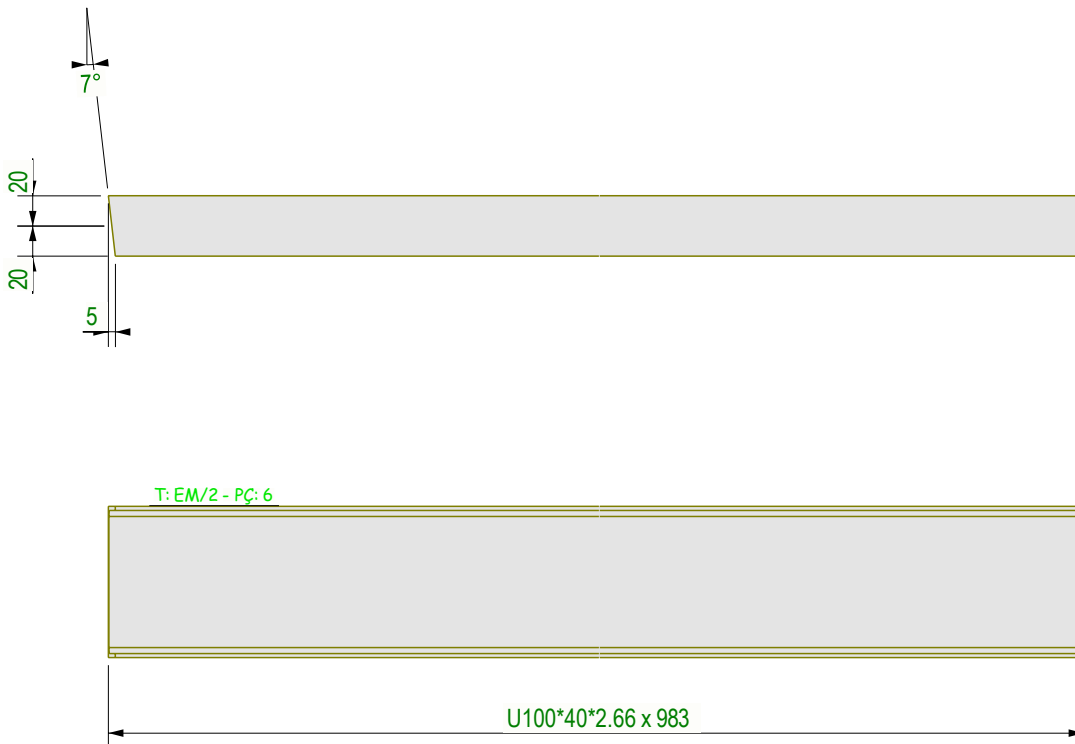

No. 18. Marc. EM/2

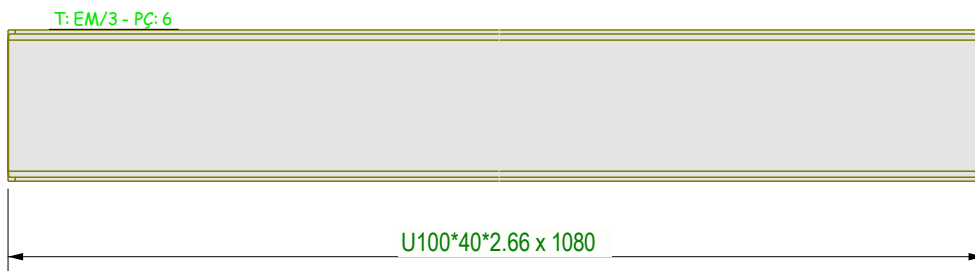
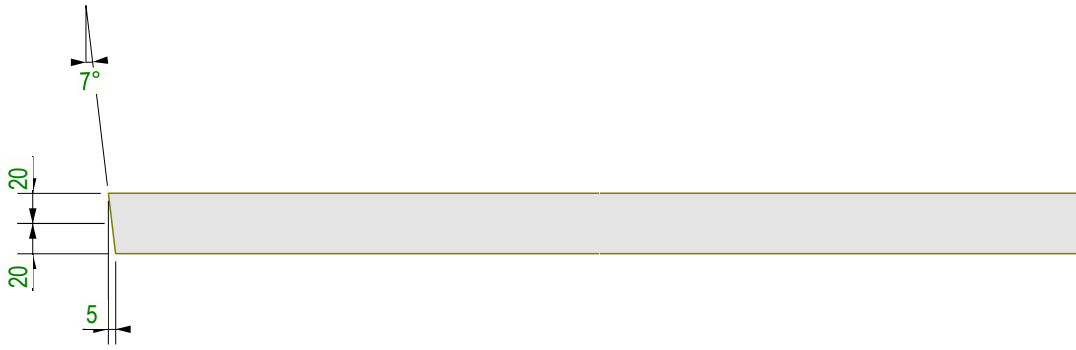

No. 18, Marc. EM/3

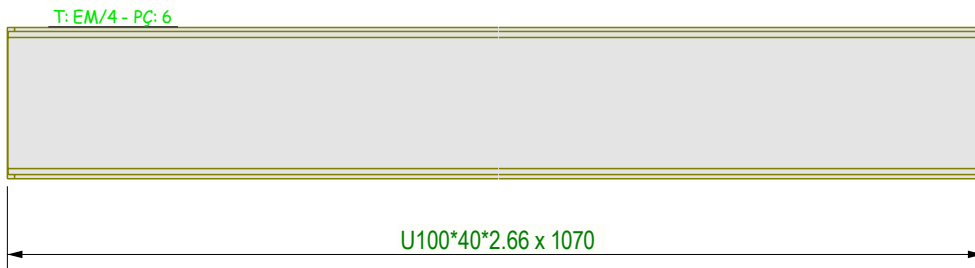
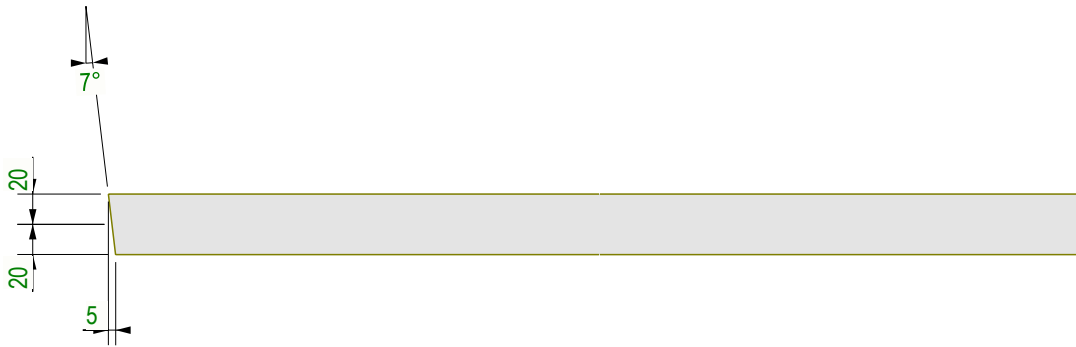

No. 18, Marc. EM/4

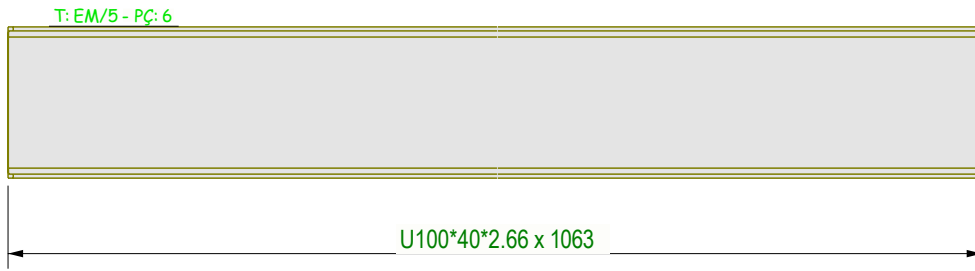
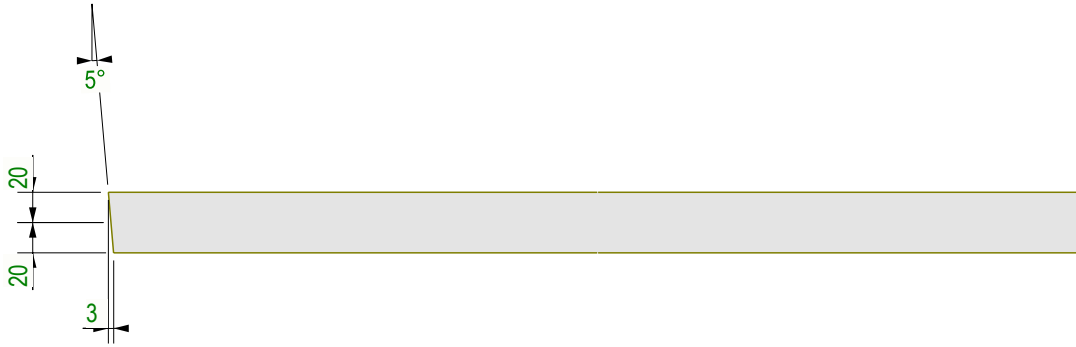

No. 18, Marc. EM/5

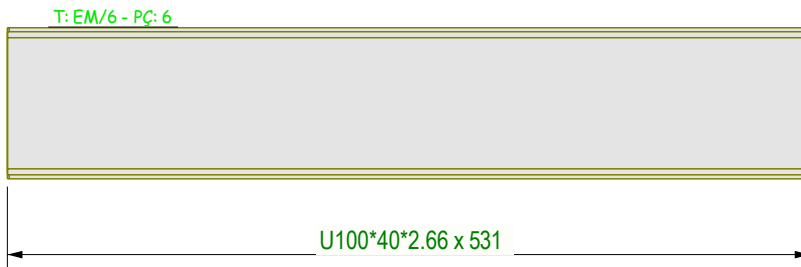
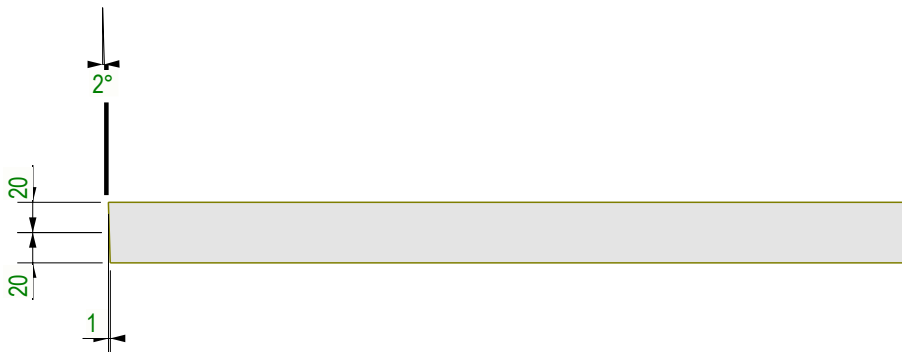

No. 18, Marc. EM/6

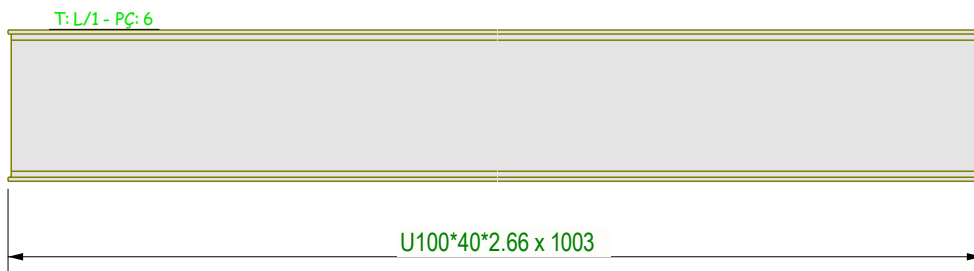
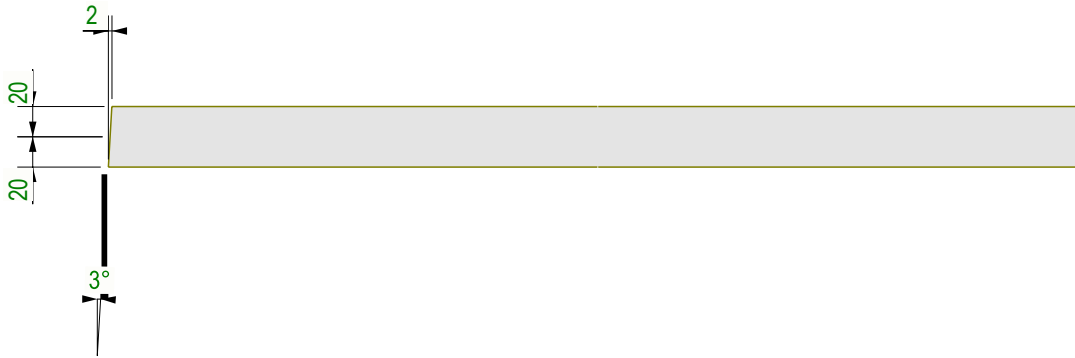

No. 18, Marc. L/1

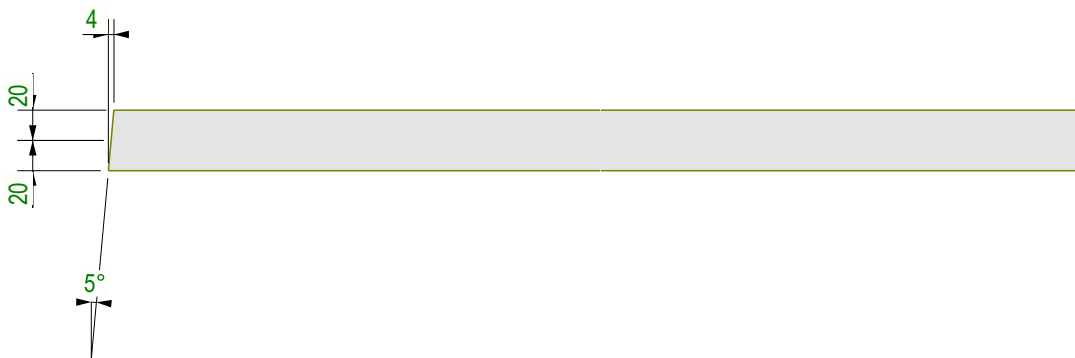

No. 18, Marc. L/2

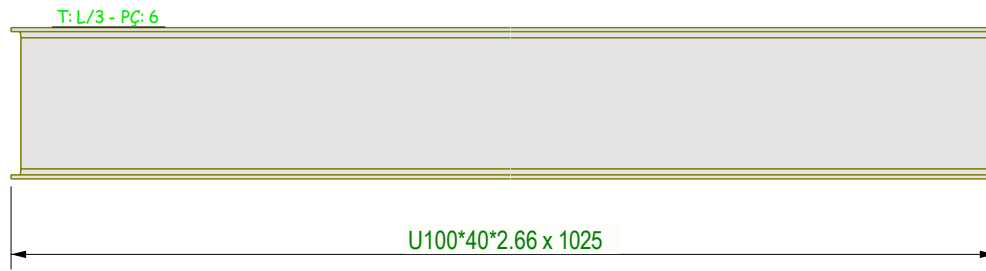
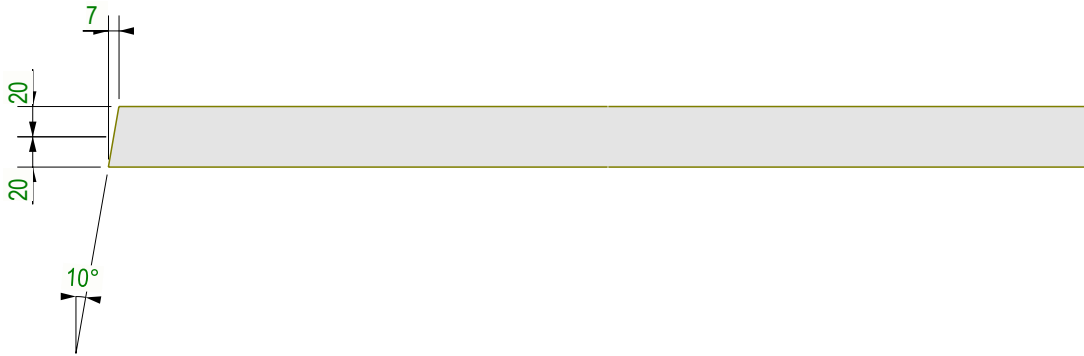

No. 18, Marc. L/3

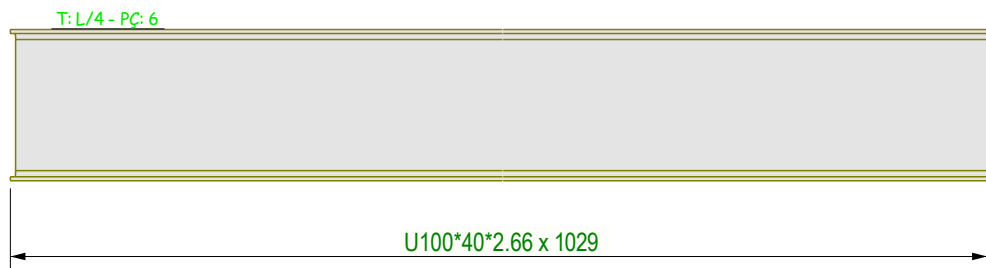
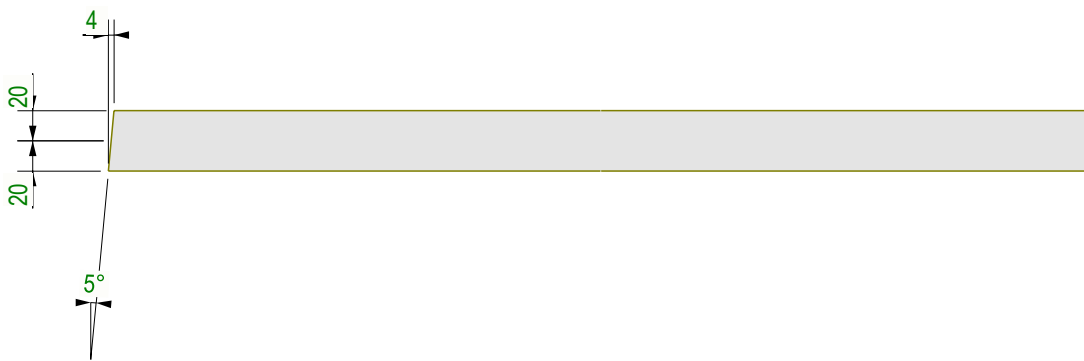

No. 18, Marc. L/4

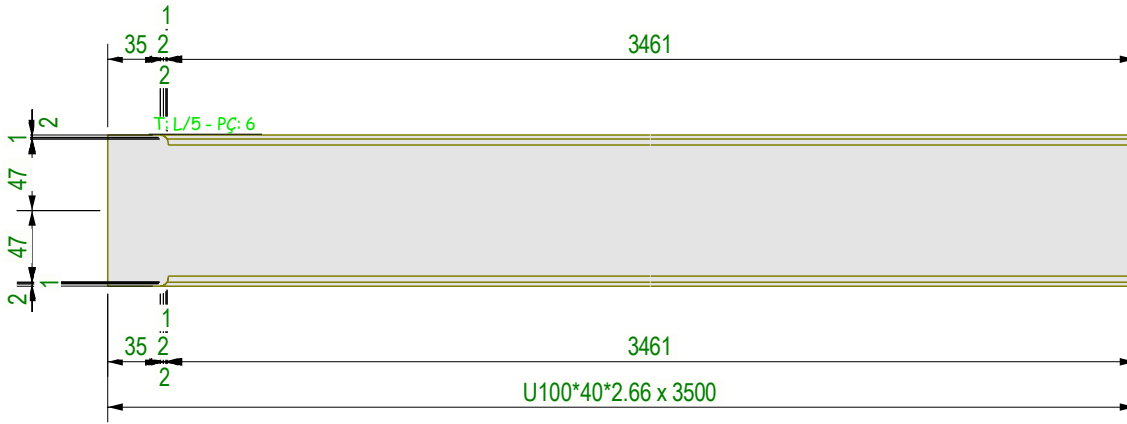
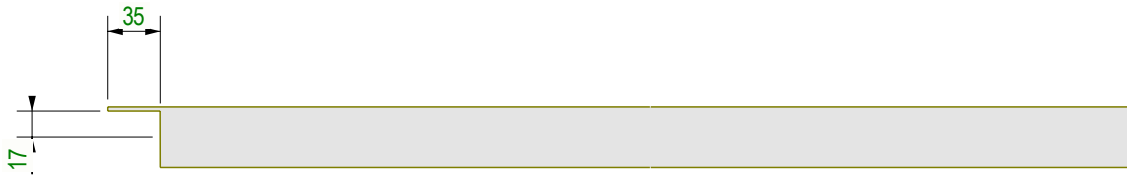

No. 18, Marc. L/5

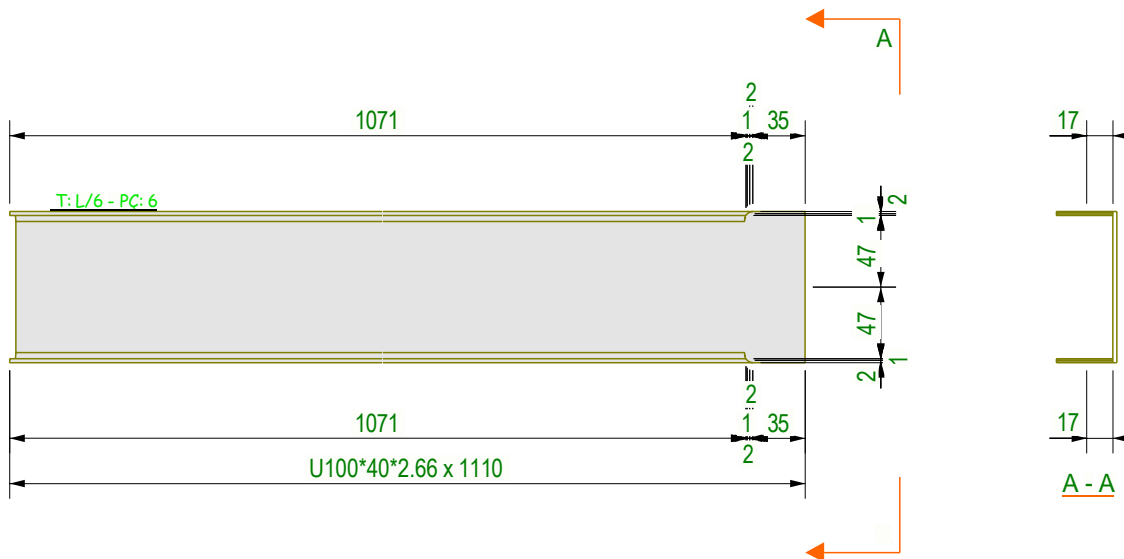
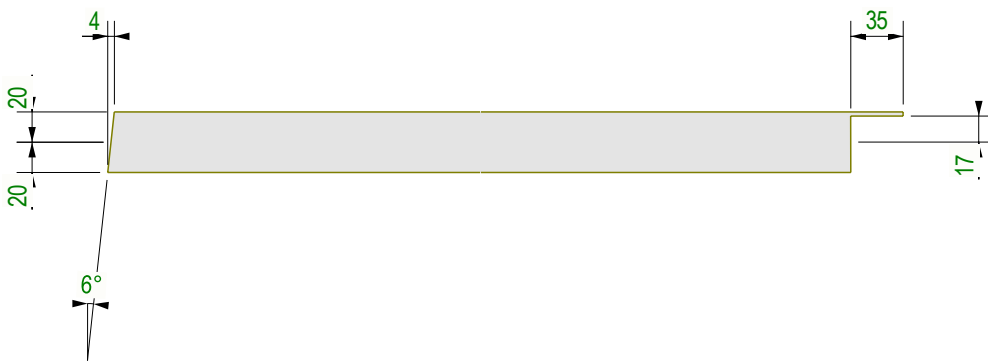

No. 18, Marc. L/6

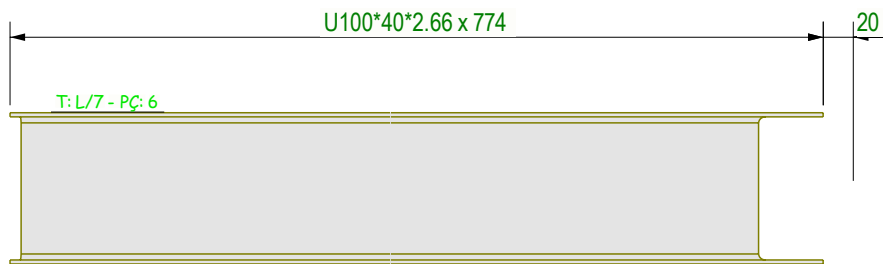
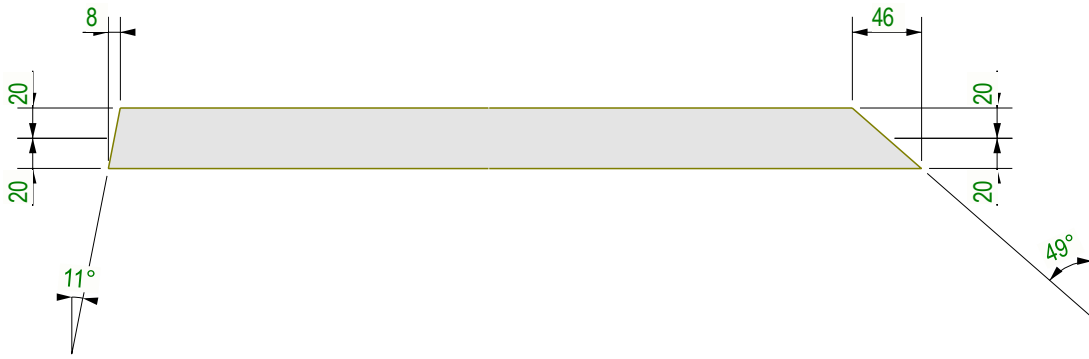

No. 18, Marc. L/7

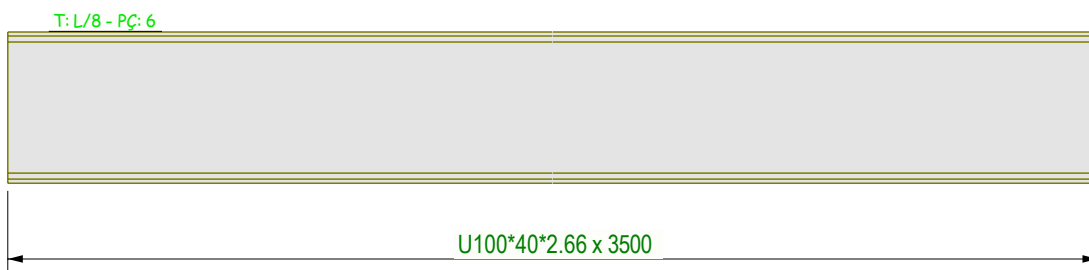

No. 18, Marc. L/8

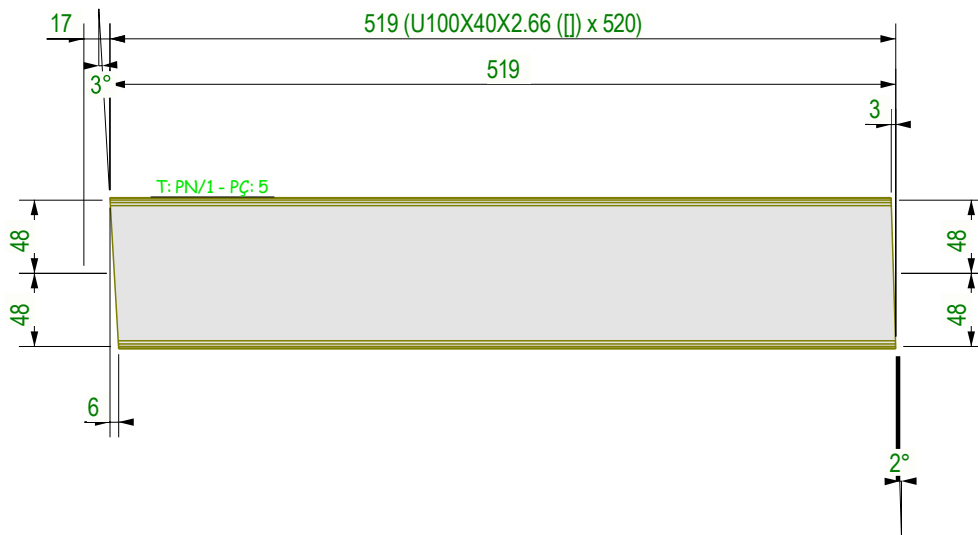

No. 9, Marc. PN/1

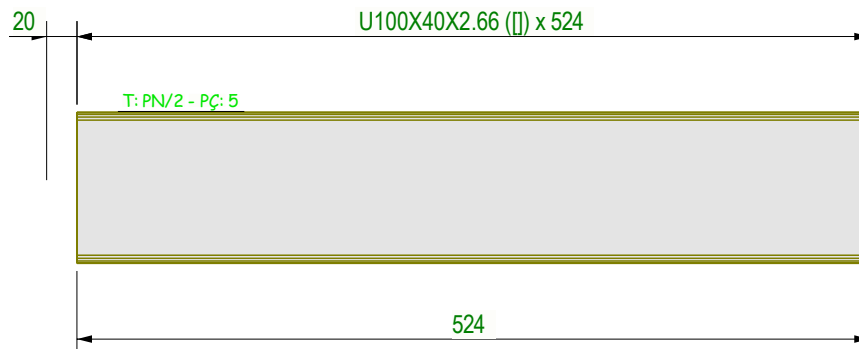

No. 18, Marc. PN/2

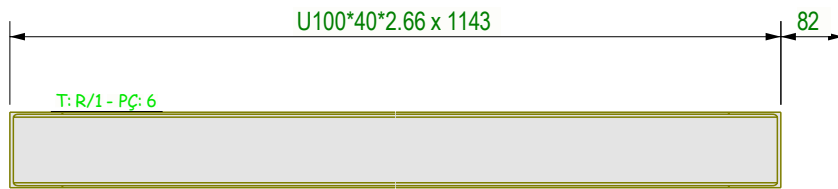
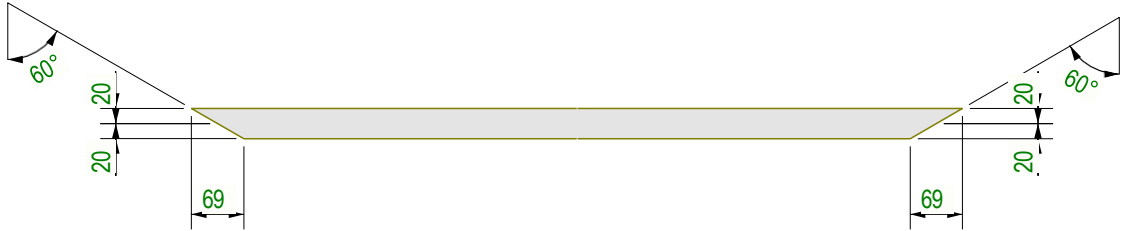

No. 18, Marc. R/1

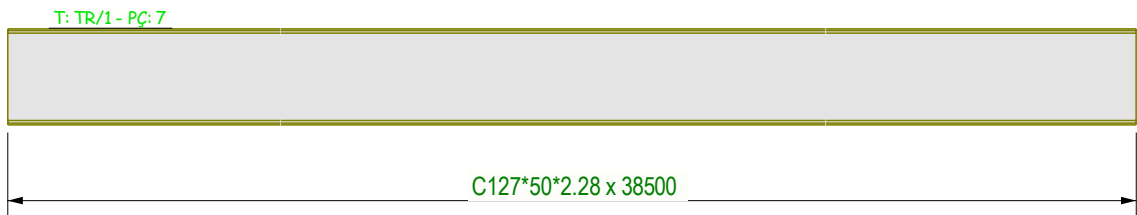

No. 15, Marc. TR/1

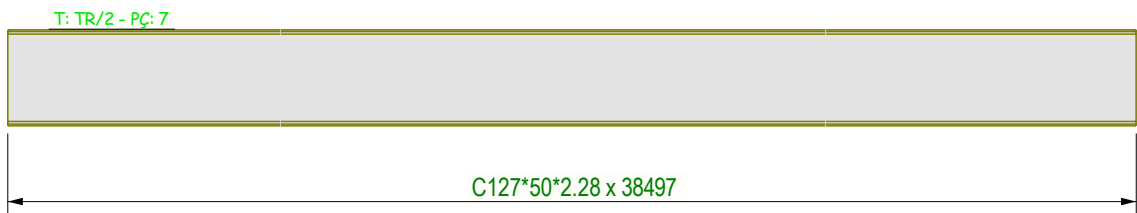

No. 1, Marc. TR/2